



WALKABILITY AUDIT TOOL

November 2011



Walking and Access Unit, Sustainable and Active Transport
Department of Transport Level 8 140 William Street Perth
Tel: 08 6551 6158 www.transport.wa.gov.au/walking

Disclaimer:

Any representation, statement, opinion or advice expressed or implied in this publication is made in good faith and on the basis that the government, its employees and agents are not liable for any damage or loss whatsoever which may occur as a result of action taken or not taken (as the case may be) in respect of any representation, statement, opinion or advice referred to herein. Professional advice should be obtained before applying the information contained in this document to particular circumstances.

Acknowledgements:

The Walkability Audit Tool is based on work conducted by the Australian Road Research Board (ARRB) for the Department of Transport in May 2011 and revised by Department of Transport Walking and Access Unit staff following feedback from members of the project team who reviewed and trialled the audit tool.

Alice Haning (Department of Transport)
Jillian Woolmer (Department of Transport)
Ruth Balding (City of Swan)
Jasmine Hancock (City of Swan)
Margaret Brophy (City of Belmont)
Victoria Brown (City of Bayswater)
Hilke Harms (ARRB)

Thank you to all the organisations and individuals who were members of the Walkability Audit Tool Project Team and provided assistance in the development of this tool:

Australian Road Research Board
City of Bayswater
City of Belmont
City of Joondalup
City of Swan
Department of Planning
Department of Transport
Eastern Metropolitan Regional Council
Physical Activity Taskforce
Public Transport Authority
Shire of Mundaring
Town of Bassendean
Town of Victoria Park
Western Australia Local Government Association

Published by the Department of Transport
140 William Street
PERTH WA 6000

T: 08 655 16000
www.transport.wa.gov.au
communications@transport.wa.gov.au
First published July 2011
Version 3 November 2011
© Western Australia

Contents

1.0	INTRODUCTION.....	1
1.1	Active transport.....	1
1.2	Walking in WA	1
2.0	Walkability Audit Tool.....	4
2.1	Methodology to work out ratings for the audited site	4
2.1.1	Section and Overall Rating	4
2.1.2	Final Report	5
3.0	ORGANISING THE AUDIT	6
3.1	Audit team	6
3.2	Selecting the routes.....	6
3.3	Selecting the day and time	7
3.4	Required equipment	7
3.5	Pedestrian design standards	8
3.6	Characteristics of pedestrians	8
3.6.1	Type of pedestrians.....	8
3.6.2	Pedestrian operating space and clearances	9
4.0	HOW TO USE THE WALKABILITY AUDIT FORMS.....	12
4.1	Form 1 – General Information and Overall Impression.....	12
4.2	Form 2 - Pathways	13
4.2.1	Type of path	13
4.2.2	Width of path and capacity.....	15
4.2.3	Condition of path.....	15
4.2.4	Obstructions on the path.....	16
4.2.5	Connectivity of the path.....	17
4.2.6	Use of the footpath by wheelchairs, prams and mobility-impaired ...	18
4.3	Form 3 - Crossings	21
4.3.1	Types of crossings	21
4.3.2	Location of crossing	22
4.3.3	Ability to cross.....	23
4.3.4	Condition of the crossing.....	23
4.3.5	Access crossing by wheelchairs, prams and mobility-impaired.....	24
4.4	Form 4 - Street Furniture and Signage	25
4.4.1	Street furniture and shade.....	25
4.4.2	Signage.....	26
4.5	Form 5 - Personal Safety.....	27
4.6	Form 6 – Adjacent Traffic	28
4.7	Form 7 - Aesthetics and Amenities.....	30
	BIBLIOGRAPHY	31
5.0	APPENDICES.....	34
	APPENDIX 1 - WALKABILITY AUDIT REPORT TEMPLATE	35
	APPENDIX 2 – WALKABILITY AUDIT FORMS	39

1.0 INTRODUCTION

Walking is an enjoyable, convenient and healthy mode of travel. It is the most popular way to replace short car trips in metropolitan Perth, however, often the street infrastructure or vehicle traffic conditions deter people from walking.

1.1 Active transport

Creating neighbourhoods that encourage people to choose active travel is increasingly being recognised as a way to foster more sustainable, healthier and safer communities. Accessible communities are inclusive communities that meet the needs of walkers, cyclists, children, seniors and people with disabilities.

In recent years high vehicle ownership levels, urban sprawl and a focus on the movement function of streets. These factors have led to an increase in car dependence and neighbourhoods which are poorly serviced for active travel. Increasingly, the focus has been on roads as corridors for the movement of cars, rather than streets as a shared movement space and the focus of life and activity. This has caused an increasing reliance on the car for transportation even for short distances, with the resulting consequences of increased traffic congestion, sedentary behaviour, ill health and social alienation.

Although a clear mandate for accessible communities has been identified in a number of high level cross-sectoral government strategies, such as Directions 2031 and beyond: Metropolitan planning beyond the horizon (Department of Planning 2010), Liveable Neighbourhoods (Western Australian Planning Commission 2007) and Walk WA: A walking strategy for Western Australia 2007-2020 (Premier's Physical Activity Taskforce 2007). There is often insufficient emphasis and profile placed on accessible communities during the land development process, resulting in developments that do not address some important aspects of accessibility.

The Eastern Metropolitan Regional Council's (EMRC) Regional Integrated Transport Strategy (RITS) Action Plan 2010-2013 (EMRC 2009) also identified the need for a proactive and strategic approach to facilitating walking within the region. Most residents travel to, from and within the region by private vehicle. The use of alternative transport modes such as public transport, walking or cycling is low. Given this, ensuring that a proactive approach is taken to facilitating a safe and enjoyable environment for walking is of great importance.

1.2 Walking in WA

Every day, Perth residents make more than 250,000 private car trips that are less than one kilometre. These trips are equivalent to a 10 minute walk, and could therefore easily be replaced by walking.

Findings from the Premier's Physical Activity Taskforce Adult Physical Activity Survey 2006 indicated that:

- Walking for recreation (63%) and for transport (32%) were the most popular physical activities in 2006. Participation in transport-related

walking increased in 2006 to 32% from 26% over the same time period. More men and women are walking for transport in 2006.

- Local streets/paths were identified as the most frequently used facilities for physical activity (49%), followed by the home (48%). Approximately 25% of Western Australians reported using walking or cycle paths, an increase from 1999 (10%).

In a survey conducted by the Department of Transport in 2008, the most common places that people would walk to were the shops, friend's house, parks, beaches or river. These local destinations are usually within a 2 km radius. Respondents also said that they would walk more if encouraged to do so and if there were good walking paths.

In addition, the results from the Perth and Regional Travel Survey (2006) conducted by Department of Planning indicated that for all person trips on an average weekday in the school term, 11.1% are walk (all the way) trips. Majority of these trips are educational, shopping and recreational trips. The average walk distance for a home based trip (where both the origin and destination of the trip are from the person's home) is 740 metres.

For all trip purposes for distances of up to 1 km, about one half (47.5%) of all trips are walk trips and 25.8% for distances up to 3 kms. The average walking speed for all walk trips is 3.3 kph.

The vision of the Walk WA: A Walking Strategy for Western Australia (2007 – 2020) is that 'by 2020, Western Australia will be a vibrant, safe, accessible place with a supportive walking environment where all Western Australians enjoy walking for health, recreation and transport'.

The Strategy defines four aspects that create a supportive walking environment and assist to contribute to the achievement of the walkability targets and goals set in the various strategies:

- **Access** – easy to reach walks and attractive public open spaces for people of all physical activity levels and abilities. Ensuring facilities are accessible to seniors, people with disabilities, and people with prams through such treatments as ramps, wide pathways, large signs and unisex toilets, will also benefit people who wish to walk in and through their local communities. Access issues may also include suitable provision of bus stops, car parking and bike racks.
- **Aesthetics** – an environment offering pleasant, clean surroundings in which to walk. The location has a natural or developed attractiveness that encourages people to use it. Considerations may include heritage preservation, litter control and excellence in landscaping.
- **Safety and security** – walkers must feel that they and their belongings are safe. People need to feel that they can relax and enjoy their walk on paths that are well maintained, stable and built with personal safety as a priority. Security is also important and walking environments should be

created or enhanced using the principles of 'designing out crime' (adapting environmental design principles for crime prevention).

- **Comfort** – walkers can be confident of shelter, conveniences and rest stops. Amenities such as drinking water, seating and shade or shelter must be available.

Liveable Neighbourhoods (Western Australian Planning Commission 2007) also emphasises the need for walkable environments, which is incorporated in the following aims:

- to provide for an urban structure of walkable neighbourhoods clustering to form towns of compatible mixed uses in order to reduce car dependence for access to employment, retail and community facilities
- to ensure that walkable neighbourhoods and access to services and facilities are designed for all users, including those with disabilities
- to provide for access generally by way of an interconnected network of streets which facilitate safe, efficient and pleasant walking, cycling and driving
- to ensure active street-land use interfaces, with building frontages to streets to improve personal safety through increased surveillance and activity.

The Austroads Guide to Road Design part 6A: Pedestrian and Cyclists Paths (Austroads 2009a) also identified five key attributes of an environment required to encourage walking referred to as the 5Cs:

- **Connected** – are there walking networks to give good access to key destinations?
- **Comfortable** – do local facilities meet design standards for footpath width, walking surfaces and planning for people with impairments?
- **Convenient** – can streets be crossed easily, safely and without delay?
- **Convivial** – are routes interesting, clean and free from threat?
- **Conspicuous** – are walking routes clearly signposted and are they published in local maps?

2.0 WALKABILITY AUDIT TOOL

The Walkability Audit Tool is a tool for use by officers of local government authorities, consultants and community groups to identify issues to improve pedestrian safety, accessibility and amenity, identify appropriate countermeasures, and document the findings of the situation in an audit report to develop an action plan for the Council.

Walking audit tools are useful in two ways. First they flag what an auditor needs to check so that a street is audited in a comprehensive way. Secondly audit tools ensure audits are conducted in consistent and comparable way and that outcomes are recorded and can be compared.

This document provides information on how to organise an audit, the standards for pedestrian facilities and how to use the forms with supporting information when conducting an onsite audit.

The audit tool consists of a series of sections in each form under each of the specific heading below:

- Form 1 – General Information and Overall Impression
- Form 2 – Pathways
- Form 3 – Crossings
- Form 4 – Street Furniture and Signage
- Form 5 – Personal Safety
- Form 6 – Adjacent Traffic
- Form 7 – Aesthetics and Amenities

The forms are designed in such a way that the auditor has the opportunity of rating the environment and recording comments whilst in the field. In addition, the guidelines also provide detailed information on the specific aspects the auditor should be aware of and look out for when completing the audit. Each section can be rated separately and the final score is used to ascertain the walkability of the site. Forms 1-7 and a report template are included in the appendices.

2.1 Methodology to work out ratings for the audited site

The audit of the selected site could be undertaken by one or several officers using the forms at appendix 2. To determine how walkable the site is, a rating system is available to ensure objectivity is being applied by the various auditors.

The ratings are classified into: 1 = unsatisfactory, 2 = unsatisfactory but acceptable and 3 = if they are satisfactory.

2.1.1 Section and Overall Rating

Each section on the forms 1-7 has an overall rating. The auditor chooses the rating which best reflects the overall rating for the area. If there are two or three unsatisfactory ratings within a section the overall rating would be unsatisfactory (1).

A judgement call needs to be made regarding unsatisfactory ratings. If there is only one unsatisfactory rating the overall rating may be unsatisfactory but acceptable (2), but if it is dangerous it could be still rated as unsatisfactory (1).

If all the aspects are considered satisfactory, the overall rating for that section is satisfactory (1).

The rating for each section are then summarised and added up on form 1 showing the section and total rating. This will enable a clear identification of the problem areas in the various sections audited. Higher ratings indicate a more walkable environment.

When the audit is undertaken by several people, each auditor's rating could be added up in total and averaged to obtain an overall rating for each audit section. It is possible to complete a partial audit and average the ratings for that section, across the number of forms used. Use your discretion when doing this to ensure that important factors that affect walkability in the area are not omitted or given a lesser priority.

2.1.2 Final Report

The final report should contain all the findings, recommendations and an action plan to address inadequate or unsafe pedestrian facilities and provide better pedestrian amenities. The report could be used by local government engineers/planners and other appropriate staff to ensure that action is properly implemented.

The Walkability Audit Report should include the following information:

1. Introduction
2. Background
 - audit location
 - audit characteristics
3. Findings and recommendations for each section audited
4. Conclusions and corrective actions.

A copy of the Audit Report Template is available at appendix 1.

3.0 ORGANISING THE AUDIT

3.1 Audit team

The pedestrian safety and accessibility audit should be completed by an auditor or audit team that has experience in pedestrian facility design and / or planning. Accredited road safety auditors would be useful on the team, but anyone with an interest in community accessibility issues and walking promotion could also use the audit tool such as community services staff, travelsmart officers and staff responsible for completing Disability Access and Inclusion Plans.

3.2 Selecting the routes

Before beginning the walkability audit the specific routes and road sections that will be audited should be defined. The selected route will depend on the reasons for undertaking the audit, for example walkability from public transport to residential or employment areas, within a whole neighbourhood or within a town centre / community shopping area. It is recommended that the auditable routes are drawn on a map of the area, and that this map is consulted when performing the walkability audit. The map can be obtained via GIS, Google Maps or simply a photocopy of the area from a road map.

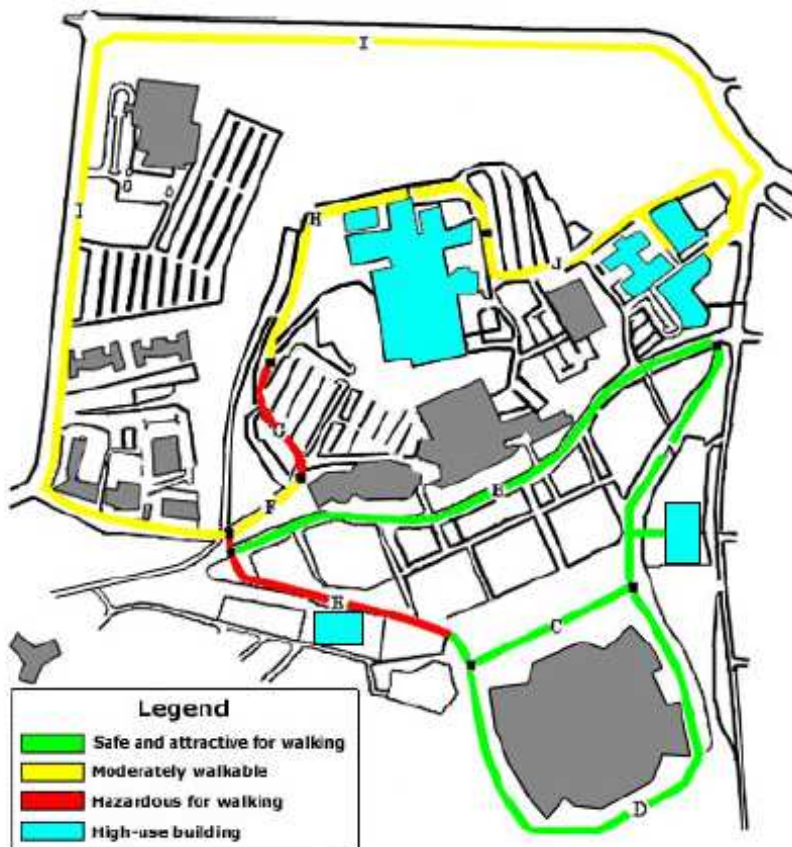

Figure 1: Example of map of routes and sections

The routes defined should be subdivided into sections, in order to assess and rate parts of the route individually. There is no maximum or minimum length of a

section or number of sections per route; however it is advisable to split routes by sections of similar characteristics and at logical points. Logical splitting points are, for example, road crossings or ends of pathways. Characteristics that might define a section are, for example, paths through a park, through a shopping street, through a residential area or alongside a railway line or busy road.

Figure 1 shows an example of a map showing the routes and sections that formed part of a walkability audit.

A smaller area can be audited or a number of sections can be audited at different times. Information gained via driving around the area or viewing Google Maps, can assist with the planning of the routes and enable generalisation of the type of walking environment. It is essential that the audit is done by foot to discover all the issues associated with the area.

3.3 Selecting the day and time

Walkability audits can be undertaken at any time, but items such as traffic conditions, pedestrian congestion and light will affect the walking level of service. In order to get a feeling for the use of the pedestrian routes the walkability audit should be performed at a time when a large number of users are walking. Such times differ based on the purposes for which people use the route and land uses in the area. Recommended times to perform the audit include during the journey to and from work for routes to public transport, during lunch breaks or on Saturdays for shopping and community areas or during Sunday mornings or afternoons for recreational routes.

Another variable that should be considered when selecting the day and time of the audit is the possibility of hazards at a specific time; for example the conflicts with heavy vehicle use or significant traffic congestion. The characteristics of a route might change significantly at night. When it is required to incorporate the review of lighting during night-time, the walkability audit should be undertaken both during daytime and night-time. The walkability audit during night-time should only focus on the aspects related to any characteristics that change the level of service when it is dark.

3.4 Required equipment

The following equipment is required to undertake the walkability audit:

- one copy of the walkability tool per section to be audited
- map of the audit area, clearly showing the audit route sections
- clipboard to hold the forms and act as a writing surface
- a small ring binder if several sections are to be audited together
- pen or pencil (plus a spare)
- camera and mobile phone (for emergencies)
- stopwatch/timer
- tape measure.

3.5 Pedestrian design standards

The design standards for pedestrian facilities are included in the Austroads Guides to Traffic Management and Road Design and the Australian Standards. The parts of these guidelines that include the most relevant information about pedestrian infrastructure are:

- Guide to Road Design Part 4: Intersections and Crossings
- Guide to Road Design Part 6A: Pedestrian and Cyclist Paths
- Guide to Traffic Management Part 4: Network Management
- Guide to Traffic Management Part 7: Traffic Management in Activity Centres
- Guide to Traffic Management Part 8: Local Area Traffic Management
- Guide to Traffic Management Part 12: Traffic Impacts of Developments
- Guide to Road Safety Part 3: Speed Limits and Speed Management
- Australian Standards 1158: Lighting for roads and public spaces
- Australian Standards 1428: Design for access and mobility
- Australian Standards 1742: Manual of uniform traffic control devices
- Australian Standards 1743: Road signs – specifications.

3.6 Characteristics of pedestrians

3.6.1 Type of pedestrians

Pedestrians have a wide range of characteristics and needs and their requirements differ significantly between pedestrian types. According to the Austroads Guide to Traffic Management (Austroads, 2009b) the pedestrian types that require special consideration are children, pedestrians with disabilities and elderly pedestrians. All users require consideration throughout the pedestrian network, but these three categories, especially people with disabilities suffering some form of functional loss or mobility impairment, need extra attention. The difficulties and considerations of these pedestrian types are noted in table 1.

Table 1 : Pedestrians requiring special considerations

Category	Difficulties	Consideration
Children	Inability to understand consequences, lack of cognitive ability	<ul style="list-style-type: none"> ▪ Require supervision ▪ Safe routes to school
Pedestrians with disabilities	Mobility (wheel chairs), vision impaired	<ul style="list-style-type: none"> ▪ Require access to all pedestrian areas ▪ Need additional infrastructure to provide guidance ▪ Continuity of treatment
Aged pedestrians	Mobility (low speed, walking frames, wheel chairs), reduced vision, loss of confidence and more easily confused	<ul style="list-style-type: none"> ▪ Low incline routes ▪ Access to public transport ▪ Personal safety

Source: Austroads (2009b).

3.6.2 Pedestrian operating space and clearances

Body depth and shoulder width are the primary human measurements used by designers of pedestrian spaces and facilities, where shoulder breadth is the factor affecting the practical capacity. The plan view of the average adult male human body occupies an area (the body ellipse) of about 0.14 m². However, a 460 mm by 610 mm body ellipse equivalent to an area of 0.21 m² is used to determine practical standing capacity, allowing for the fact that many pedestrians carry personal articles, natural psychological preferences to avoid bodily contact with others and body sway (figure 2).

With respect to normal path operation where pedestrians and cyclists are moving at speed and sharing space it is considered that a 1 m width should be used as the basis of design to allow adequate operating space and clearances for pedestrians.

Whilst there is a wide variation in the size of people and their reach, basic limits that should be adopted for the purposes of design (figure 3). As can be seen, anything that must be reached by wheelchair users and people with mobility difficulties should lie between approximately 600 mm and 1.57 m above the ground. Things in this range are generally also accessible by children and people of short stature.

Clearance for knuckles of hands is included in figure 3. The radius is the swept path of the wheelchair, clearance between path and objects (for example walls, poles) must be provided. Wheelchair users are also constrained in the limits of their horizontal reach (figure 3).

Dimensions of the design wheelchair (wheelchairs vary in size) and reach limits are shown in figure 4, which also shows space requirements for a wheelchair to

be turned. Wheelchair users generally require more space than other people to move around. A wheelchair generally needs 1.2 m of clear space for comfortable movement whilst people using crutches have a similar requirement. In contrast most walkers require 900 mm of clear space. More room is required for people to pass each other. Two wheelchair users can pass each other in a space 1.8 m wide. This is also enough room for a user to turn a wheelchair around.

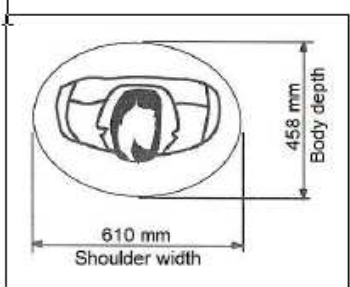

Source: Austroads (2009a).

Figure 2: Plan view of pedestrian body ellipse

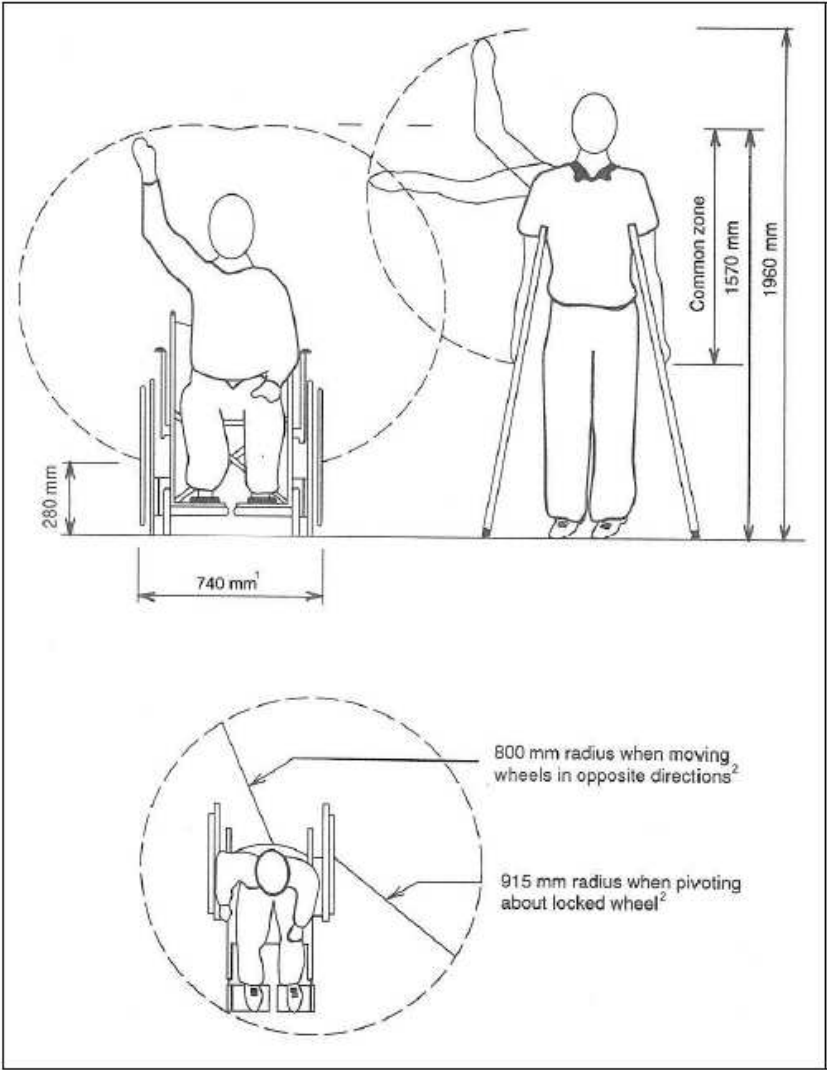

Source: Austroads (2009a)

Figure 3: Design dimensions for mobility impaired people

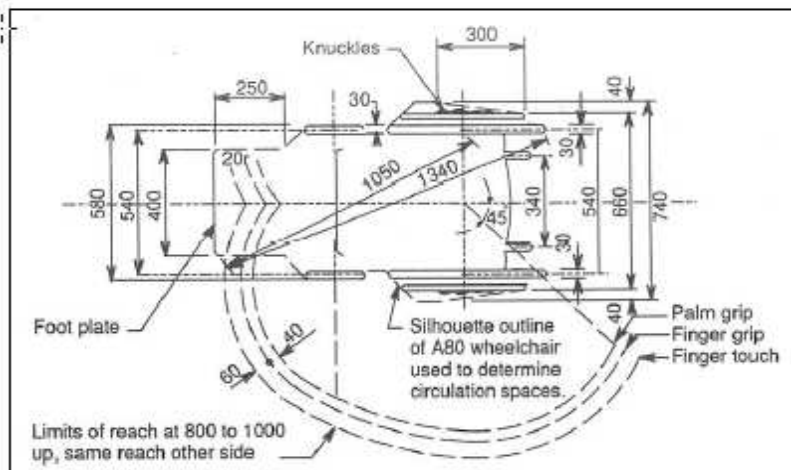
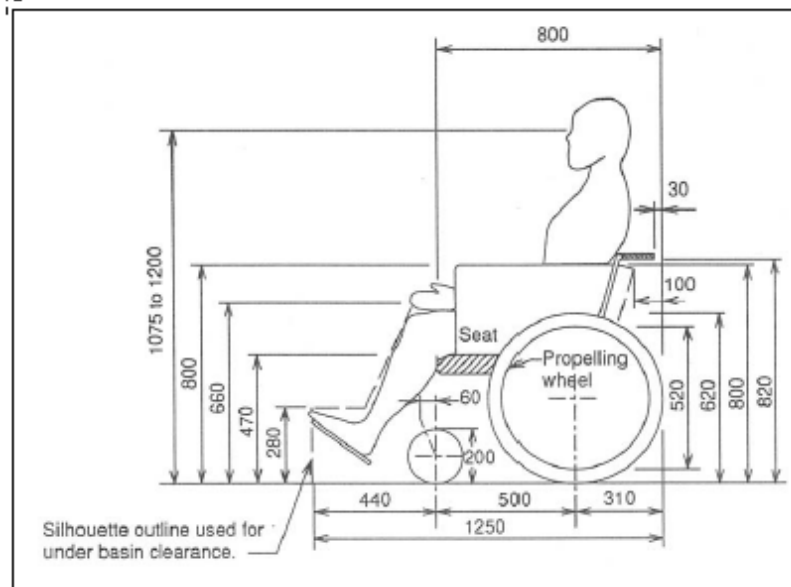

Source: Austroads (2009a)

Figure 4 : Wheelchair dimensions

4.0 HOW TO USE THE WALKABILITY AUDIT FORMS

The walkability audit tool consists of seven topic areas, which are included on separate forms in order to make it possible to audit a specific topic on its own. Each topic contains a number of questions, sometimes divided by sub-categories.

Form 1 includes general information about the area and a Summary Form for completion after sections have been audited. Forms 2 to 7 should be completed for each route section separately. The walkability audit tool is included in appendix 2 and includes the following:

1. General information and Overall Impression
2. Pathways
3. Crossings
4. Street Furniture and Signage
5. Personal Safety
6. Adjacent Traffic
7. Aesthetics and Amenities.

The walkability audit forms incorporate a rating for each category and sub-category. The sub-category can be rated on a scale of 1-2-3, where 1 is unsatisfactory and 3 is satisfactory. The method of rating the overall category is based on the same scale described for each sub-category in the tool.

The auditor is given the opportunity to include comments on each section of the form. It is recommended to include as many comments as appropriate, as this makes it easier to write the audit report after the audit. Photographs can contain more information than words; therefore it is recommended that many photographs are taken to strengthen your observations and that the approximate location photographs are taken are marked on the map.

4.1 Form 1 – General Information and Overall Impression

The first walkability audit tool form is used to collect general information on the area and routes including:

- auditor/audit team members
- date, time and location of the audit
- land uses of the area
- primary users of the area
- purpose of the audit
- weather conditions during the audit
- overall impression of walkability in the area.

A Summary Form is at the bottom of Form 1 to enable a quick overview of the audit results. It is recommended that ratings are listed here for all forms and sections, after the audit is completed.

4.2 Form 2 - Pathways

Form 2: Pathways includes information about the pathways in the audit area and consists of six sub-categories:

- Path Type
- Path Width
- Path Condition
- Path Obstructions
- Path Connectivity
- Path Accessibility for People With Disability

4.2.1 Type of path

This part of the form includes information about the type of path that is present on the route section and the use of this facility. It might be possible that different types of paths are present along the route or that the situation changes. It is advisable to mark and number the different type of paths on the map of the area and refer to the specific section of the path when adding comments.

The audit tool incorporates the following questions:

- What type of path is present (figure 5)?
- Is the path provided on both sides of the road?
- In which direction of travel is most of the pedestrian traffic on the path?
- Is the path sufficient for the pedestrian (and cyclist) volumes and type of users?

There are various types of paths used by pedestrians including:

- pedestrian path or footpath – the most common type of path is a footpath for use by pedestrians and young cyclists (depending on local road rules).
- pedestrian path adjacent to property boundary – often includes driveway crossings, boundary visual obstructions and deviations at side streets.
- pedestrian path adjacent to the kerb – often with hazards such as temporary obstructions including wheelie bins once per week or yearly verge side collections.
- shared use path – built to meet the demand of both a pedestrian path and a bicycle path but where the intensity of use is not expected to be high enough to warrant separate facilities. Pedestrians and bicyclists mix, but

bicyclists must give way to pedestrians. The path should be wider than a footpath and have adequate kerb ramps and signage. Faster bike riders should be catered for with on road bike lanes to reduce path user conflict.

- separated path – are built when volume of both cycling and pedestrians are high and shared use causes safety and operational problems. A separated path is a path where cyclists and pedestrians are required to use separate designated paths, created by the use of pavement markings, contrasting surfaces, and the erection of regulatory signs.



Shared use path symbol



Separated path symbol



Shared use path with bike/walk symbols on path



Separated path with bike path separated from the pedestrian path to the right of the hedge



Pedestrian path adjacent to property boundary



Pedestrian path adjacent to the kerb

Figure 5: Type of paths

4.2.2 Width of path and capacity

The width of the footpath is dependent on its location, purpose and the anticipated demand on the facility. Width requirements for footpaths, including provisions for people with disabilities such as vision impairment and wheelchairs, are shown in Table 2. As a guide, the desirable minimum width of a footpath that has a very low demand is 1.2 m with an absolute minimum of 1.0 m. These widths should be increased at locations where:

- high pedestrian volumes are anticipated
- a footpath is adjacent to a traffic or parking lane
- a footpath is combined with bicycle facilities
- the footpath is to cater for people with disabilities.

Table 2 : Width requirements for footpaths

Situation	Desired width (m)	Comments
General low demand	1.2 to 1.0 (absolute minimum)	General minimum is 1.2 m for most roads and streets Clear width required for one wheelchair Not adequate for commercial or shopping environments
High pedestrian volumes	2.4 (or higher based on demand)	Generally commercial and shopping areas
For wheelchairs to pass	1.8 to 1.5 (desired minimum)	Allow for two wheelchairs to pass (1.8 m comfortable, 1.5 m minimum) Narrower width (1.2 m) can be tolerated for short distances
For people with other disabilities	1.8 to 1.0	-

The auditor should measure the width of the footpath and advise whether the width provided appears sufficient for the situation; this is covered by the following two questions of the audit form:

- What is the average width of the footpath?
- Is the footpath width sufficient for the pedestrian (and cyclist) volumes and type of users?

4.2.3 Condition of path

The overall condition of the footpath relates both to the original design of the footpath and whether there are any repair or maintenance needs. Footpaths should not consist of dangerous footpath surfaces that could cause people to fall and injure themselves. A footpath should be designed in a way that the

pavement is smooth and slip resistant. The pavement surface should be free of uneven levels, tripping hazards, minor uplifts and lips. A well maintained footpath is free of cracking, buckling, holes, damaged pavement, weeds, protruding tree roots, overgrown vegetation, standing water and loose debris (figure 6).

An adequate footpath provides sufficient headroom for the users; this means the footpath is free of overhanging foliage and low mounted road signs or sun screens.

Within this topic the auditor should answer the following questions on the audit form:

- Is the walking surface of the footpath appropriately designed?
- Is the pavement of the footpath well maintained?
- Is the headroom of the footpath sufficient?



Figure 6 : Poor maintenance and design of footpath

4.2.4 Obstructions on the path

The effective width of the footpath is dependent on the existence of permanent and temporary obstructions. Permanent obstructions are for example street signs, bus stop shelters, street furniture like trash cans and benches, trees, bushes, post boxes, poles, parking meters, lamp columns or street art (figure 7). At some locations permanent obstructions do not cause any hazards as the remaining width of the footpath is still sufficient (left picture in figure 7). However, permanent obstructions might also make the path unattractive for pedestrians (right and middle picture in figure 7).

Temporary obstructions are items that appear irregularly and are temporarily fixed to the footpath; for example parked bicycles, parked cars, wheelie bins on rubbish days, portable signs, seats of cafes and restaurants or shop stands (figure 8). Just as with permanent obstructions, temporary obstructions might be located so that the width of the footpath is not affected, or the footpath is narrowed too much.



Figure 7 : Permanent obstructions on footpath

The auditor should check the existence of permanent and temporary obstructions and should measure the effective width of the path and evaluate whether this is still sufficient for the pedestrian (and cyclist) volumes and type of users on the path. The walkability audit tool includes the following questions on this topic:

- Is the path clear of permanent or temporary obstructions?
- At the location of obstruction(s) what is the minimum width of the path?
- Is the effective width of the path at the location of obstruction(s) sufficient for the pedestrian (and cyclist) volumes and type of users?



Figure 8 : Temporary obstructions on path

4.2.5 Connectivity of the path

The connectivity of the footpath to key destinations and other footpaths in the area to form a pedestrian network is very important for the walkability in an area. Even small gaps in the network of footpaths can make a whole area unusable for some pedestrians. A missing section might prevent passage by pedestrians with mobility impairments and may be muddy and unpleasant for any other

pedestrians (figure 9). If a footpath suddenly 'ends' pedestrians will either need to retrace their path and find another route, or cross the road at an unsafe crossing point. Regular users will know there is poor pedestrian access along this route, which might result in a low level of patronage.

The auditor should answer the following questions on the form:

- Is the pedestrian facility provided continuous; does it have any missing sections?
- Is the pedestrian facility connected to other facilities to form a pedestrian network?
- Is the pedestrian facility provided connected to key destinations along the route (like public transport stops, schools, shops, parks, community centres, offices)?



Figure 9: Abruptly ending footpath on missing (unpaved) section of footpath

4.2.6 Use of the footpath by wheelchairs, prams and mobility-impaired

The characteristics of footpaths to be used by disabled people and pedestrians with mobility impairments and pedestrians with prams might vary from the requirements of other users. While reviewing the footpaths the auditor should be very aware of:

- whether the surface of the footpath is smooth enough to be used by wheelchairs and prams
- whether ramps are provided as an alternative to stairs
- whether level landings, handrails or other facilities are provided to support pedestrians with mobility impairments at sloping surfaces (both gradient and cross fall).

Longitudinal gradients (or running slope) should be as flat as possible (such as two percent) where there is likelihood that disabled persons will use the path. While the standards in AS 1428.1 and AS 1428.2 were designed for buildings,

there is the need to consider the same requirements for paths and include landings or rest areas where required.

Crossfall (or cross slope) is the slope of the footpath at right angles to the direction of travel. Some crossfall is required for drainage, but excessive crossfall results in difficult conditions for pedestrians with wheelchairs or walking frames, who have to exert extra energy to resist the sideways forces. Crossfall in the through-route zone should always be between one and two percent while steeper crossfalls can be created in the Street Furniture and/or Frontage Zone. AS 1428.1 – 2001 specifies that any crossfall should not exceed 1:40 (two point five percent). A flatter crossfall may be adopted provided that drainage is facilitated to avoid any ponding of water within the path.

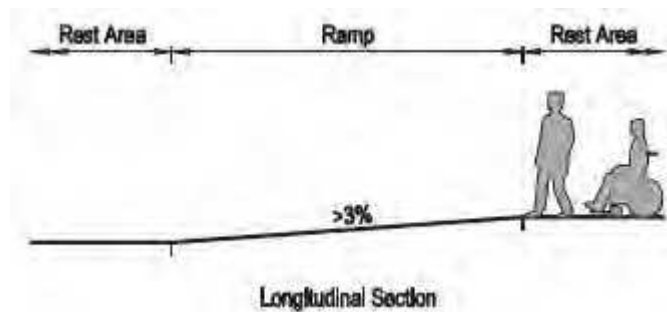

Landings (rest areas) in ramp with a longitudinal gradient or running slope

(Source: NZ Transport Agency, Pedestrian Planning and Design Guide, 2009)

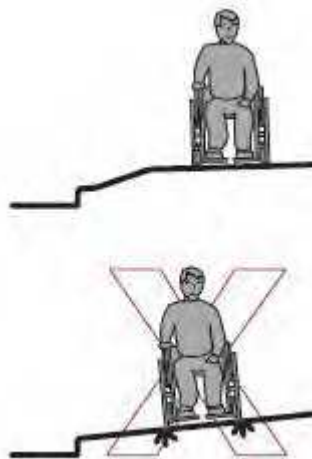

Correct and incorrect provision of crossfall

(Source: NZ Transport Agency, Pedestrian Planning and Design Guide, 2009)

Ramp definition

A ramp is an inclined accessway that has a constant gradient anywhere between 1:14 and 1:20. Steeper gradients present problems of endurance for

ambulant pedestrians and manual wheelchair users. Steeper gradients can cause instability and loss of control for users of wheeled mobility aids. Some people, especially those with a walking aid find ramps difficult to negotiate and may prefer a set of steps. Due to natural topography some paths are on steep hills with gradients greater than 1:14. Efforts must be made to decrease these gradients especially in higher pedestrian areas. If it is technically not possible, building in landings at close intervals that act as resting points, providing handrails for support and / or some form overhead protection against inclement weather may assist.

Ramp and footpath landings

Landings provide an opportunity for pedestrians to rest and a flat surface for wheelchairs to change direction. The minimum dimensions that will enable most wheelchairs users to rest or change direction as specified in AS1428.1 Clause 10 are:

- 1200mm long for a straight ramp
- 1500mm long for a 90 degree turn
- 1540mm wide by 2070mm long,
- assuming two 1000mm wide parallel paths with a 70mm gap in between, for a 180 degree turn.

Ramp Specifications	Gradient	Landings Required
A ramp with	a gradient of 1:14	at least every 9 metres
A ramp with	a gradient of 1:20	at least every 15 metres
A ramp with	gradients in between	require calculation of intervals by linear interpolation

Landings (rest areas) in ramp

(Source: NZ Transport Agency, Pedestrian Planning and Design Guide, 2009)

Footpath Specifications	Gradient	Landings Required
A footpath with	a gradient of 1:20	at least every 15 metres
A footpath with	a gradient of 1:33	at least every 25 metres
A footpath that is	flatter than 1:33	does not require landings
A path with	gradients in between	require calculation of intervals by linear interpolation

4.3 Form 3 - Crossings

Form 3: Crossings can be completed for each route section separately, although it might be possible that several crossing points are located within one route section. It is recommended to mark and number each crossing in the route section on the map of the area. While completing the form, refer to the crossing number when adding comments. The crossings form includes five sub-categories:

- type of crossing
- location of crossings
- ability to cross
- condition of the crossing
- access to the crossing by wheelchairs, prams and mobility-impaired persons.

4.3.1 Types of crossings

The type of the pedestrian crossing provided needs to be appropriate for the size of the road and the amount of traffic at peak hours. Major roads tend to have signalised crossings with pedestrian traffic lights. On smaller roads zebra crossings or the provision of kerb ramps are sufficient. Median islands are useful to allow people to cross to the centre of the road and then wait for a safe crossing to the far side of the road. On stretches of roads where people cross at various places (such as retail strips) central medians over the whole length of the road might be present.

This section of the audit form includes information about the type of pedestrian crossing facilities that are present in the route section. It includes the following questions:

- What type of pedestrian crossing facilities are present (figure 10)?
- How many traffic lanes do pedestrians have to cross?
- Are median islands provided to allow pedestrian to cross in two stages?
- Is the crossing facility sufficient for the type of road, size of the road, volume of traffic, pedestrian volumes and type of pedestrians?



Median island



School crossing



Pedestrian signals with pushbuttons



Zebra crossing

Figure 10 : Types of pedestrian crossing facilities

4.3.2 Location of crossing

Being unable to safely cross the road is one of the key reasons why people choose not to walk. Pedestrians usually prefer to travel in the most direct route possible. If blocks are excessively long, or if crossings do not provide safe and accessible routes that directly connect the destinations people want to reach, many pedestrians will walk or cross outside the provided pedestrian infrastructure.

This section of the walkability tool looks at the location of the crossing points, and includes the following questions:

- Are sufficient crossings provided?
- Are crossings located at logical locations?
- Do pedestrians correctly use the crossing points provided?
- When pedestrian crossing is prohibited are pedestrians directed to better crossing locations, with physical barriers and signs (figure 11)?



Figure 11: Pedestrian crossing prohibited

4.3.3 Ability to cross

Pedestrians who must wait for an excessive amount of time to cross a street may walk against a pedestrian signal or cross at another location. The auditor should check whether the traffic signals allow enough time to cross the road safely and whether the waiting time at traffic lights is sufficient in order to deter people from ignoring the pedestrian signals. At unsignalised crossings the auditor should check whether there are sufficient gaps in the traffic flow and whether these gaps are large enough to allow pedestrians to cross the road safely.

The following questions for signalised intersections are included in the audit tool:

- Do the traffic signals allow enough time to cross the road safely?
- Is the waiting time short enough to discourage people from ignoring the pedestrian signals?

The following question for unsignalised intersections is included:

- Are there sufficient gaps in the traffic flow and are they large enough to allow pedestrians to cross the road safely?

4.3.4 Condition of the crossing

Just as with the condition of the footpath the overall condition of the crossing relates both to the original design of the path and to whether there are any repair or maintenance needs. A crossing should be designed in a way that the pavement is smooth and slip resistant. The pavement surface should be free of uneven levels, tripping hazards, minor uplifts and lips. In addition the design of the crossing should:

- allow sufficient room to accommodate the expected pedestrian volumes at the waiting area
- mark the cross walk; the marking should be wide enough, at a logical location and clearly visible
- include kerb ramps and waiting areas that are lined up with the crosswalk, including those on median islands and other refuge areas.

A well maintained crossing is free of cracking, buckling, holes, damaged pavement, weeds, protruding tree roots, overgrown vegetation, standing water and loose debris.

The walkability audit tool incorporates the following questions on this topic:

- Is the pavement of the crossing adequately designed?
- Is the pavement of the crossing well maintained?
- Is the waiting area sufficient to accommodate the expected pedestrian volumes?
- Is the crosswalk sufficiently well marked, wide enough, at a logical location and clearly visible?
- Are the kerb ramps and waiting areas lined up with the crosswalk, including those on median islands and other refuge areas?

4.3.5 Access to the crossing by wheelchairs, prams and mobility-impaired

Special facilities should be provided at the crossing points to support and assist pedestrians with mobility impairments or limited vision. The accessibility of the crossing should be audited via the following questions:

- Are kerb ramps provided at the kerb sides and on median islands or other refuge areas, to accommodate wheelchairs and prams?
- Is the slope from the footpath to the road safe, smooth and comfortable to use?
- Are the waiting areas, including those at median islands and other refuge areas level? (refer to left picture in figure 12 for an example of an uneven waiting area)
- Is sufficient manoeuvring space available at waiting areas in order to accommodate wheelchairs and prams? (see figure 4, wheelchair users generally require more space than other people to move around. A wheelchair generally needs 1.2 m of clear space whilst most walkers require only 900 mm. Two wheelchair users can pass each other in a space 1.8 m wide or one user can turn a wheelchair around)?
- Can vision impaired pedestrians identify the crossing, are tactile surfaces provided (figure 12)?
- Can children and people in wheelchairs reach the pushbuttons of signalised crossings?

- Do the pedestrian signals have audio-tactile devices for vision impaired pedestrians?



Figure 12 : Provision of tactile surfaces for vision impaired pedestrians

4.4 Form 4 - Street Furniture and Signage

4.4.1 Street furniture and shade

The attractiveness of an area for walking depends on the existence of street furniture, provision of shaded areas and facilities for pedestrians such as signage. Good walking routes have an adequate supply of seating, shelters and rubbish bins. Street furniture includes benches, rubbish bins, drinking fountains and public restrooms.

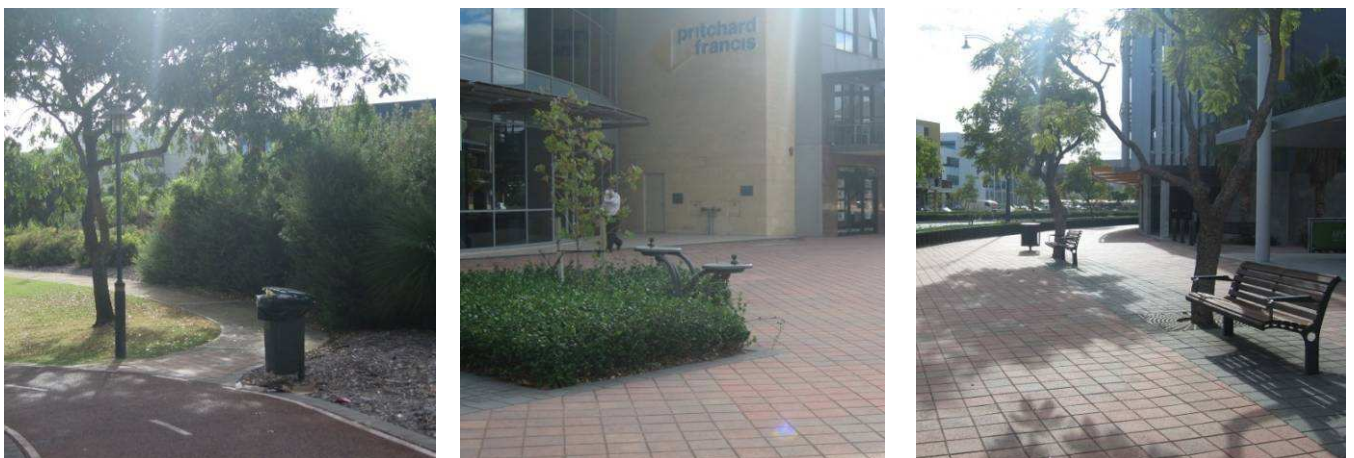

Figure 13 : Types of street furniture

The auditor should check to see if these facilities are provided along the route section and whether they are well maintained. They should also check whether sufficient shade is provided to the footpath and waiting and resting areas. Big trees provide excellent shade; verandas, shade cloths or sails and other type of shelters are useful in places where trees are not appropriate (figure 14).



Figure 14 : Provision of shade on the footpath

The auditor should answer the following questions on this topic:

- What type of street furniture is provided along the route section?
- Is the street furniture in good condition (no damage or graffiti)?
- Is shade provided to the footpath by trees or structures?
- Is shade provided at resting places and other places with street furniture by trees or structures?

4.4.2 Signage

Good signage along the routes should be present to guide and direct pedestrians to the key destinations, help people to navigate around and warn motorists about the presence of pedestrian facilities (figure 15). Directional signs assist pedestrians in finding their route to the key destinations in the area as do street name signs on street corners. Warning signs and pavement markings warn motorists about the presence of pedestrians in the area and increase safety for pedestrians.

The walkability tool form includes the following questions on this topic:

- Is signage provided to guide and direct pedestrians to the key destinations in the area?
- Are street names clearly visible to pedestrians?
- Are pedestrian routes and crossings clearly visible to motorists by the use of pedestrian warning signs and pavement markings?

- Are pedestrian crossings clearly visible to pedestrians by markings and signs?
- Is the type of pedestrian infrastructure clearly marked?
- Is the condition of signage and markings adequate (for example, well-painted, non-slippery material, visible during day and night, not damaged or not worn)?



Figure 15 : Pedestrian signage

4.5 Form 5 - Personal Safety

Public spaces including footpaths, parks, shopping strips and school areas should feel safe for people to walk around. A lack of safety or even a feeling of unease will decrease the attractiveness and hence utilisation of an area dramatically. Well lit areas and open spaces make an area more attractive for walking. Having people around and having houses or (business) buildings in proximity to the path increases the ‘passive surveillance’ of the area. Passive surveillance is one of the best ways to help people feel safe, both during the day and at night. During night-time the streets and crossings should be well lit. As a rule, street lighting should be bright enough to be able to see other people’s faces and see any obstructions or potholes / trips and slips. The lighting at crossings should be twice as bright as at footpaths.

The auditor should check the personal safety of the area both during daytime and night-time, as the characteristics of the area might change significantly when it is dark. The daytime section of the form includes the following questions:

- Do you feel safe walking on this route section?
- Is the path visible from adjacent land uses and activities?
- Are there enough people around to make you feel safe?
- Are underpasses well lit during daytime?

The night-time section of the form includes the following questions:

- Do you feel safe walking on this route section during night-time?
- Is the path visible from adjacent land uses and activities during night-time?
- Are there enough people around on the street to make you feel safe during night-time?
- Are pathways well lit during night-time?
- Are crossings well lit during night-time, so motorists can see pedestrians crossing?
- Are underpasses well lit during night-time?

4.6 Form 6 – Adjacent Traffic

The speed limit and volume of traffic passing the pedestrian routes is one of the main reasons why people do not feel safe or do not find the route attractive. The walkability audit tool focuses on the following questions related to issues on the interaction between pedestrians and traffic:

- Is the traffic speed or volume of motorised traffic satisfactory for pedestrian safety and amenity?
- Are there any devices or design characteristics used to slow down the traffic or reduce the traffic volume (for example speed humps, median islands, chicanes, roundabouts and extended kerbs) (figure 16)?
- Is there adequate separation distance or a barrier (for example safety rail, bollard, trees, street furniture, lighting columns or vegetation) provided between motorists and pedestrians (figure 17)?

If the footpath is also used by other traffic (for example cyclists, skateboarders and other recreational devices/users) is it well designed for this purpose with no resulting hazards and conflicts?



Figure 16 : Design characteristics to slow down traffic

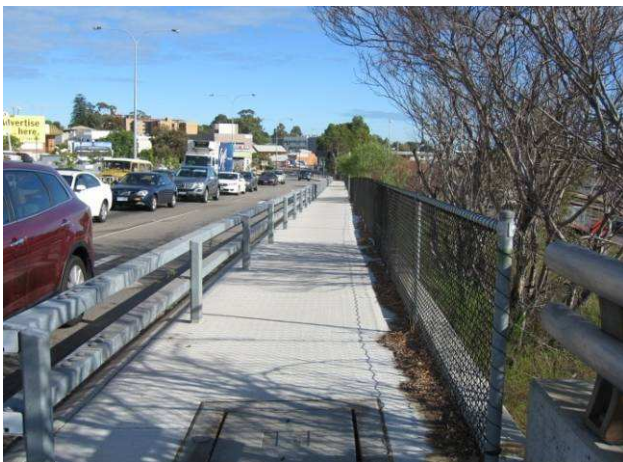

Figure 17 : Design characteristics to provide distance between pedestrians and cars

The walkability audit tool also looks at specific issues at crossings and driveways; this includes the following questions:

- Are parked vehicles clear of the pedestrian crosswalks?
- Are drivers aware of the presence of pedestrians and do they give way to pedestrians (at for example zebras, driveways, loading docks and when turning left)?
- Is oncoming traffic clearly visible to pedestrians at crossings (no obstructions blocking the sight line and all pedestrians, including children and people in wheelchairs can see approaching vehicles)?
- Is the driver's sight distance to the pedestrian crossing adequate (are all types of pedestrians, including children and people in wheelchairs, visible to approaching vehicles and is the driver's vision uninterrupted)?
- Does the footpath continue uninterrupted through driveway crossovers?

4.7 Form 7 - Aesthetics and Amenities

The walkability of an area relies in part on its attractiveness and pleasantness. A pedestrian route is attractive if landscaping, public artwork, building and shop fronts and green areas and vegetation are present (figure 18). In addition the area should be free of litter, dumped rubbish, discarded items, graffiti, air pollution and noise pollution.

The audit form incorporates the following questions on this topic:

- Is the route section attractive and pleasant to walk around?
- Is the route section clear of litter, dumped rubbish, discarded items and graffiti?
- Is the route section clear of air pollution (for example diesel fumes and factory emissions)?
- Is the route section clear of noise pollution (for example construction, factories and traffic)?

Does the route section provide pedestrian oriented features (for example benches, drinking fountains or rubbish bins)?

BIBLIOGRAPHY

Abley Transportation Consultants Limited 2010, *Community Street Review How to Guide – Part 1: Background, Walkability and Planning*, NZ Transport Agency and Living Streets Aotearoa, New Zealand.

Abley Transportation Consultants Limited 2010a, *Community Street Review How to Guide – part 1: Background, Walkability and Planning*, NZ Transport Agency and Living Streets Aotearoa, New Zealand.

Abley Transportation Consultants Limited 2010b, *Community Street Review How to Guide – part 3: Results and Publication*, NZ Transport Agency and Living Streets Aotearoa, New Zealand.

Active Living Research 2009, *Walking Route Audit Tool*, San Diego State University and University of California, USA, <http://www.activelivingresearch.org/node/11950>, viewed March 2011.

Active Living Research 2003, *Analytic Audit Tool and Checklist Audit Tool*, Saint Louis University School of Public Health, USA, http://www.activelivingresearch.org/files/audit_tool_analytic.pdf and http://www.activelivingresearch.org/files/audit_tool_checklist.pdf, viewed March 2011.

Austrroads 2009a, *Guide to Road Design Part 6A: Pedestrian and Cyclists Paths*, by G. Veith, AGRD06A/09, Austrroads, Sydney, NSW.

Austrroads 2009b, *Guide to Traffic Management Part 4: Network Management*, by J. Bliss, P. Freeman and A. Wall, AGTM04/09, Austrroads, Sydney, NSW.

Centre for Disease Control 2010, *Healthier Worksite Initiative Walkability Audit Tool*, U.S. Department of Health and Human Services, USA, http://www.cdc.gov/nccdphp/dnpao/hwi/downloads/walkability_audit_tool.pdf viewed July 2011.

City of Perth 2009, *Perth Public Spaces and Public Life Study*, City of Perth, Perth, WA, <http://www.perth.wa.gov.au/web/Council/Plans-and-Projects/Current-Plans-and-Studies/> viewed July 2011.

Department of Planning and Western Australian Planning Commission 2010, *Directions 2031 and beyond – metropolitan planning beyond the horizon*, Western Australian Government, Perth, WA

Eastern Metropolitan Region Council 2009a, *Regional Integrated Transport Strategy Action Plan 2010 – 2013*, EMRC, Belmont, WA, Australia.

Heart Foundation n.d., *Health Urban Environments Site Assessment Audit*, Heart Foundation, VicHealth, SunSmart, Planning Institute Australia – Victoria Division, VIC, <http://www.heartfoundation.org.au/SiteCollectionDocuments/ABD%20HUE%20Site%20Audit%20Tool.pdf>, viewed March 2011.

- Living Streets n.d., *Creating Healthy Environments – Practical Tools for Increasing walking in the Built Environment*, Living Streets, UK, <http://www.livingstreets.org.uk/take-action/our-projects/creating-healthy-environments/>, viewed March 2011.
- Nabors D, M Gibbs, L Sandt, S Rocchi, E Wilsom, M Lipinski 2007, *Pedestrian Road Safety Audit Guidelines and Prompt List*, Federal Highway Administration Office of Safety, Washington, USA.
- NZ Transport Agency, *Pedestrian Planning and Design Guide*, 2009.
- Perth Metropolitan Transport Group 1995, *Perth Metropolitan Transport Strategy*, Department of Transport, Fremantle, WA.
- Premier's Physical Activity Taskforce 2007, *Walk WA: A Walking Strategy for Western Australia 2007-2020*, Government of Western Australia Department of Sport and Recreation, Perth, WA.
- Queensland Government 2006, *Pedestrian Safety and Accessibility Audit Tools*, Queensland Government, QLD, http://www.transport.qld.gov.au/resources/file/eb1fc80275a963e/Pdf_pedestrian_safety_and_accessibility_audit_tools.pdf, viewed March 2011.
- Stollof E, J Barlow 2008, *Pedestrian Mobility and Safety Audit Guide*, AARP Driver Safety Program & Mobility Options, and Institute of Transportation Engineers (ITE), USA.
- Saelens B, J Sallis, J Black & D Chen 2002, *Neighbourhood Environment Walkability Scale (NEWS)*, University of Sydney, Sydney, NSW, <http://www.cpah.health.usyd.edu.au/pdfs/NEWS.pdf> and <http://www.cpah.health.usyd.edu.au/pdfs/NEWSscoring.pdf>, viewed March 2011.
- Transport for London 2010, *The Pedestrian Environment Review System (PERS)*, London, UK, <http://www.trl.co.uk/pers.htm>, viewed March 2011.
- Transport WA 2000, *Perth Walking: The Metropolitan Region Pedestrian Strategy*, Transport WA, Perth, WA.
- Victoria Walks 2009, *Walking Audit Tool*, Victoria Walks, Melbourne, VIC, <http://www.victoriawalks.org.au/Assets/Files/Revised%20audit%2014MAY09.doc>, viewed March 2011.
- Walkable America n.d., *Walkability Checklist*, US Department of Transport & Pedestrian and Bicycle Information Centre, USA, <http://www.walkableamerica.org/checklist-walkability.pdf>, viewed March 2011.
- Walking Info 2007, *Pedestrian Road safety Audit Guidelines and Prompt List*, US Department of Transportation, USA, <http://katana.hsrb.unc.edu/cms/downloads/PedRSA.reduced.pdf>, viewed March 2011.

Western Australian Planning Commission 2007, *Liveable Neighbourhoods – Edition 3*, WAPC, Perth, WA.

5.0 APPENDICES

Appendix 1 Walkability Audit Report Template

Appendix 2 Walkability Audit Forms

WALKABILITY AUDIT REPORT TEMPLATE

Introduction

Location: (could make reference to map and can be divided into sections)

Audit purpose:

Audit date:

Audit team (names):

Weather conditions:

Background

Audit location:

Audit Characteristics:

Findings and Recommendations

Finding #1: (Describe the shortfall in as much detail as you can using the information from the Walkability Audit Tool)

Recommendations:

1 – Suggest what could be done to resolve the finding

2 -

3. -

Conclusions and Corrective Actions

The overall rating of the walkability of the route is

These rating of XXXX is based on the ratings given to each audit category in section of the route during the walkability audit. (Optional to include a Chart at Appendix XX)

Summary table of recommendations and action required for each section.

Corrective action plan (example only)

	Audit recommendations	Priority High 1 Medium 2 Low 3	Intended action
Section 1 -			
1	Provide signage at the exit of thetrain station to direct pedestrians to the key destinations.		
2	Continue tactile paving to the pedestrian crossing ofStreet to guide visibility impaired pedestrians.		
3	Improve the attractiveness of the pedestrian area from the train station exit toStreet, by including artworks, landscaping features and attractive facilities.		
4	Investigate improvements to the visibility of the pedestrian crossing of Street by providing a levelled crossing/speed hump and/or colour paint on the crosswalk.		
5	Install street lighting to improve visibility during night-time on the pedestrian crossing of Street.		
6	Provide tactile paving on the kerb ramps of the pedestrian crossing ofStreet.		

	Audit recommendations	Priority High 1 Medium 2 Low 3	Intended action
Section 2			
7	Improve the visibility of the pedestrian path alongStreet. Possible solutions are 'beware of pedestrian' signage, 'give way to pedestrian' signage or use of coloured pavement on the path.		
8	Improve the smoothness of the path at the crossovers of the driveways along Street. Make sure the path continues uninterrupted through driveway crossovers.		
9	Repair the covers in the path on the north side of Street.		
10	Install a 'give way to pedestrian' sign on the intersection of Street and Street.		
11	Investigate opportunities to make the south side of Street the logical route from the train station to the shopping centre, by providing signage to use this side of the road. Provide pedestrian crossing facilities at Street and from the train station exit to the south side of Street.		

	Audit recommendations	Priority High 1 Medium 2 Low 3	Intended action
Section 3			
12	Install directional signage on the intersection ofHighway andStreet to the western entrance ofshopping centre.		
13	Install a zebra crossing to provide a safe and comfortable crossing for pedestrians at the intersection ofandStreets.		

Walkability Audit Forms

Appendix 2

Form 1 General Information and Overall Impression

1.1 General Information					
<ul style="list-style-type: none"> • Tick where appropriate and write comments or sketch in spaces available as a guide to help you write your report • Mark additional comments on map of area, including locations of photos taken to identify issues for each section 					
Auditor / Audit Team:					
Date and time:					
Audit location:			Section 1:		
Land uses:			Section 2:		
Primary users:			Section 3:		
Purpose of the audit:					
Weather conditions: <input type="checkbox"/> fine <input type="checkbox"/> rainy <input type="checkbox"/> windy <input type="checkbox"/> overcast <input type="checkbox"/> other					
1.2 Overall Impression					
General Comments					
Overall Impression Rating					
		1 unsatisfactory		2 unsatisfactory but acceptable	
				3 satisfactory	
After completion of each section for the audit – enter the overall ratings below to find out a total walkability rating (higher total = more walkable)					
Summary Form		Example	Section 1	Section 2	Section 3
1	Overall Impression	2			
2	Pathways	3			
3	Crossings	2			
4	Street Furniture and Signage	3			
5	Personal Safety	1			
6	Adjacent Traffic	3			
7	Aesthetics and Amenities	3			
Total rating		17			

Walkability Audit Forms

Appendix 2

Form 2 Pathways

Section Location (mark issues on map)					
2.1 Path Type		Yes	No	N/A	Don't know
Comments	<ul style="list-style-type: none"> • Is a path present <input type="checkbox"/> • What type? (See walkability audit tool guidelines figure 5 for photo examples) <ul style="list-style-type: none"> <input type="checkbox"/> pedestrian path <input type="checkbox"/> pedestrian path near property boundary <input type="checkbox"/> pedestrian path near kerb <input type="checkbox"/> shared use path <input type="checkbox"/> separated path <input type="checkbox"/> unpaved path <input type="checkbox"/> no facility <input type="checkbox"/> other • Is the path provided on both sides of the road? <input type="checkbox"/> • Which direction is most of the pedestrian traffic? <input type="checkbox"/> both directions <input type="checkbox"/> one direction <input type="checkbox"/> unclear • Is the path suitable for pedestrian/ cyclist volumes and types of users? <input type="checkbox"/> 	<input type="checkbox"/>	<input type="checkbox"/>	<input type="checkbox"/>	<input type="checkbox"/>
	Rating 1 unsatisfactory 2 unsatisfactory but acceptable 3 satisfactory				
2.2 Path Width and Capacity	<ul style="list-style-type: none"> • Average width of path _____ metres • Is the path wide enough to for pedestrian/cyclist volumes and types of users? (See walkability audit tool guidelines table 2 for desirable width requirements) 	<input type="checkbox"/>	<input type="checkbox"/>	<input type="checkbox"/>	<input type="checkbox"/>
Comments					
	Rating 1 unsatisfactory 2 unsatisfactory but acceptable 3 satisfactory				
2.3 Path Condition	<ul style="list-style-type: none"> • Are there any hazard or maintenance issues? (See walkability audit tool guidelines figure 6) <ul style="list-style-type: none"> <input type="checkbox"/> potholes <input type="checkbox"/> cracking <input type="checkbox"/> protruding tree roots <input type="checkbox"/> flooding <input type="checkbox"/> debris/sand/glass <input type="checkbox"/> obstructing branches <input type="checkbox"/> other _____ • Are there any design issues? <ul style="list-style-type: none"> <input type="checkbox"/> rough uneven surface <input type="checkbox"/> slippery surface <input type="checkbox"/> uplifts in pavement <input type="checkbox"/> low mounted road signs <input type="checkbox"/> other _____ • Is the head room of the path sufficient (free of overhanging foliage and low mounted signs) 	<input type="checkbox"/>	<input type="checkbox"/>	<input type="checkbox"/>	<input type="checkbox"/>
Comments		<input type="checkbox"/>	<input type="checkbox"/>	<input type="checkbox"/>	<input type="checkbox"/>
	Rating 1 unsatisfactory 2 unsatisfactory but acceptable 3 satisfactory				

Walkability Audit Forms

Appendix 2

Form 2 Pathways

		Yes	No	N/A	Don't know
2.4 Path Obstructions	<ul style="list-style-type: none"> Are there any permanent obstructions? (See walkability audit tool guidelines figure 7) 	<input type="checkbox"/>	<input type="checkbox"/>	<input type="checkbox"/>	<input type="checkbox"/>
	<input type="checkbox"/> signs <input type="checkbox"/> bus stops/shelters <input type="checkbox"/> street furniture/bins/seats <input type="checkbox"/> trees/bushes <input type="checkbox"/> poles <input type="checkbox"/> street art <input type="checkbox"/> other _____				
	<ul style="list-style-type: none"> Are there any temporary obstructions? (See walkability audit tool guidelines figure 8) 	<input type="checkbox"/>	<input type="checkbox"/>	<input type="checkbox"/>	<input type="checkbox"/>
	<input type="checkbox"/> parked bicycles <input type="checkbox"/> parked cars <input type="checkbox"/> portable signs <input type="checkbox"/> seats from cafes <input type="checkbox"/> shop stands <input type="checkbox"/> wheelie bins <input type="checkbox"/> other _____				
Comments	<ul style="list-style-type: none"> The minimum effective width of path is _____ metres Is the effective width of the path suitable for pedestrian / cyclist volumes and types of users? 	<input type="checkbox"/>	<input type="checkbox"/>	<input type="checkbox"/>	<input type="checkbox"/>
	Rating 1 unsatisfactory 2 unsatisfactory but acceptable 3 satisfactory				
2.5 Path Connectivity	<ul style="list-style-type: none"> Is it continuous (i.e. no missing sections?) (See walkability audit tool guidelines figure 9) 	<input type="checkbox"/>	<input type="checkbox"/>	<input type="checkbox"/>	<input type="checkbox"/>
	<ul style="list-style-type: none"> Is the connected to other paths to form a pedestrian network? 	<input type="checkbox"/>	<input type="checkbox"/>	<input type="checkbox"/>	<input type="checkbox"/>
	<ul style="list-style-type: none"> Is it connected to key destinations along the route? 	<input type="checkbox"/>	<input type="checkbox"/>	<input type="checkbox"/>	<input type="checkbox"/>
	<input type="checkbox"/> train station <input type="checkbox"/> bus station <input type="checkbox"/> bus stop <input type="checkbox"/> school <input type="checkbox"/> shops <input type="checkbox"/> park <input type="checkbox"/> community centre <input type="checkbox"/> offices <input type="checkbox"/> industrial area <input type="checkbox"/> other _____				
Comments					
	Rating 1 unsatisfactory 2 unsatisfactory but acceptable 3 satisfactory				
2.6 Path Accessibility (PWD)	<ul style="list-style-type: none"> Is the surface of the path suitable for use by prams, wheelchairs and mobility-impaired persons? 	<input type="checkbox"/>	<input type="checkbox"/>	<input type="checkbox"/>	<input type="checkbox"/>
	<ul style="list-style-type: none"> Are ramps provided as an alternative to stairs for people with disabilities (PWD)? 	<input type="checkbox"/>	<input type="checkbox"/>	<input type="checkbox"/>	<input type="checkbox"/>
	<ul style="list-style-type: none"> Are level landings, handrails or guard rails provided for steep walking surfaces? (see guidelines 4.2.6) 	<input type="checkbox"/>	<input type="checkbox"/>	<input type="checkbox"/>	<input type="checkbox"/>
	<input type="checkbox"/> other _____				
Comments					
	Rating 1 unsatisfactory 2 unsatisfactory but acceptable 3 satisfactory				
Form 2 Overall Pathways Rating	1 unsatisfactory 2 unsatisfactory but acceptable 3 satisfactory				

Walkability Audit Forms

Form 3 Crossings

Section Location (mark issues on map)		Yes	No	N/A	Don't know		
3.1 Type of Crossing	<ul style="list-style-type: none"> • What type of crossing is present? (See walkability audit tool guidelines figure 10 for photo examples) <ul style="list-style-type: none"> <input type="checkbox"/> median island / refuges <input type="checkbox"/> zebra <input type="checkbox"/> automatic pedestrian signals <input type="checkbox"/> pedestrian signals with pushbuttons <input type="checkbox"/> traffic lights without pedestrian signals <input type="checkbox"/> overpass <input type="checkbox"/> underpass <input type="checkbox"/> school crossing <input type="checkbox"/> no facility <input type="checkbox"/> other _____ • How many traffic lanes do pedestrians have to cross? _____ lanes 						
Comments	<ul style="list-style-type: none"> • Are median islands provided to allow pedestrians to cross in two stages? <input type="checkbox"/> • Is the crossing suitable for the type and size of road, traffic and pedestrian volumes and types of users? <input type="checkbox"/> 	<input type="checkbox"/>	<input type="checkbox"/>	<input type="checkbox"/>	<input type="checkbox"/>		
Rating		1 unsatisfactory		2 unsatisfactory but acceptable		3 satisfactory	
3.2 Location of Crossing	<ul style="list-style-type: none"> • Are sufficient crossings provided? • Are crossings at logical locations e.g. entrances/exits to key destinations or connections to other paths? • Do pedestrians use the crossing points provided correctly? • If crossing is prohibited, are pedestrians directed via physical barriers and signs to another crossing point? (See walkability audit tool guidelines figure 11) 	<input type="checkbox"/>	<input type="checkbox"/>	<input type="checkbox"/>	<input type="checkbox"/>		
Comments							
Rating		1 unsatisfactory		2 unsatisfactory but acceptable		3 satisfactory	
3.3 Ability to Cross	<ul style="list-style-type: none"> • At signalised intersection: do the traffic signals allow enough time to cross the safely? • Is the waiting time short enough to discourage people from ignoring the pedestrian signals? <p style="margin-left: 20px;">Allows _____ seconds to cross</p> <p style="margin-left: 20px;">Took _____ seconds waiting time before walking phase started</p> <ul style="list-style-type: none"> • At unsignalised intersection: Do the gaps in the traffic flow allow people to cross the road safely? 	<input type="checkbox"/>	<input type="checkbox"/>	<input type="checkbox"/>	<input type="checkbox"/>		
Comments							
Rating		1 unsatisfactory		2 unsatisfactory but acceptable		3 satisfactory	

Walkability Audit Forms

Appendix 2

Form 4 Street Furniture and Signage

Section Location (mark issues on map)		Yes	No	N/A	Don't know		
4.1 Street Furniture and Shade	<ul style="list-style-type: none"> • Is street furniture provided? <input type="checkbox"/> • What type of street furniture is present? (See walkability guidelines figure 13 for photo examples) <input type="checkbox"/> benches <input type="checkbox"/> low walls, sufficient to sit on <input type="checkbox"/> rubbish bins <input type="checkbox"/> drinking fountains <input type="checkbox"/> public restrooms <input type="checkbox"/> other _____ • Is the street furniture provided in good condition (not damaged, no graffiti etc.)? <input type="checkbox"/> • Is shade provided to the path by trees or structures? <input type="checkbox"/> • Is shade provided at resting places and areas with street furniture, by trees or structures? (See walkability audit tool guidelines figure 14 for photo examples) <input type="checkbox"/> 	<input type="checkbox"/>	<input type="checkbox"/>	<input type="checkbox"/>	<input type="checkbox"/>		
Comments							
		Rating	1 unsatisfactory	2 unsatisfactory but acceptable	3 satisfactory		
4.2 Signage	<ul style="list-style-type: none"> • Is signage provided to guide and direct pedestrians to the key destinations in the area? (See walkability audit tool guidelines figure 15 for photo examples) <input type="checkbox"/> • Are street names clearly visible to pedestrians? <input type="checkbox"/> • Are pedestrian routes/crossings clearly visible to motorists via warning signs and pavement markings? <input type="checkbox"/> • Are pedestrian routes/crossings clearly visible to pedestrians by markings and signs? <input type="checkbox"/> • Is the type of path clearly marked as a shared path, pedestrian only path etc? <input type="checkbox"/> • Are signage and pavement markings in good condition? <input type="checkbox"/> <input type="checkbox"/> well painted <input type="checkbox"/> non slippery material <input type="checkbox"/> visible day and night <input type="checkbox"/> not damaged <input type="checkbox"/> other _____ 	<input type="checkbox"/>	<input type="checkbox"/>	<input type="checkbox"/>	<input type="checkbox"/>		
Comments							
		Rating	1 unsatisfactory	2 unsatisfactory but acceptable	3 satisfactory		
Form 4 Overall Street Furniture and Signage Rating					1 unsatisfactory	2 unsatisfactory but acceptable	3 satisfactory

Walkability Audit Forms

Appendix 2

Form 5 Personal Safety

Section Location (mark issues on map)		Yes	No	N/A	Don't know		
5.1 Personal Safety Daytime	<ul style="list-style-type: none"> Do you feel safe walking on this route section during the day? Is the path visible from adjacent land uses and activities during the day? 	<input type="checkbox"/>	<input type="checkbox"/>	<input type="checkbox"/>	<input type="checkbox"/>		
	<ul style="list-style-type: none"> Are there enough people around to make you feel safe during the day? Are underpasses well lit during daytime? 	<input type="checkbox"/>	<input type="checkbox"/>	<input type="checkbox"/>	<input type="checkbox"/>		
Comments							
Rating		1 unsatisfactory		2 unsatisfactory but acceptable		3 satisfactory	
5.2 Personal Safety Night-time	<ul style="list-style-type: none"> Do you / would you feel safe walking on this route section during the night? Is the path visible from adjacent land uses and activities during the night? Are there / would there be enough people around to make you feel safe during the night? 	<input type="checkbox"/>	<input type="checkbox"/>	<input type="checkbox"/>	<input type="checkbox"/>		
	<ul style="list-style-type: none"> Is there good lighting in the area during the night? Are underpasses well lit during the night? 	<input type="checkbox"/>	<input type="checkbox"/>	<input type="checkbox"/>	<input type="checkbox"/>		
Comments							
Rating		1 unsatisfactory		2 unsatisfactory but acceptable		3 satisfactory	
Form 5 Overall Personal Safety Rating							
	1 unsatisfactory		2 unsatisfactory but acceptable		3 satisfactory		

Walkability Audit Forms

Form 6 Adjacent Traffic

Section Location (mark issues on map)		Yes	No	N/A	Don't know
6.1 Adjacent Traffic, General Traffic Issues	<ul style="list-style-type: none"> • Is the motorised traffic speed or volume satisfactory for pedestrian safety and amenity? • Are there any traffic calming devices? (See walkability audit tool guidelines figure 16 for photo examples) <ul style="list-style-type: none"> <input type="checkbox"/> speed humps <input type="checkbox"/> median islands <input type="checkbox"/> chicanes <input type="checkbox"/> roundabouts <input type="checkbox"/> projecting kerbs <input type="checkbox"/> other _____ • Is separation provided between motorists and pedestrians? (see figure 17 for photo examples) <ul style="list-style-type: none"> <input type="checkbox"/> verge <input type="checkbox"/> safety rail <input type="checkbox"/> bollards <input type="checkbox"/> trees <input type="checkbox"/> street furniture <input type="checkbox"/> lighting columns <input type="checkbox"/> vegetation <input type="checkbox"/> other _____ • Is the path used by other traffic? <ul style="list-style-type: none"> <input type="checkbox"/> wheelchairs <input type="checkbox"/> prams <input type="checkbox"/> bikes <input type="checkbox"/> scooters <input type="checkbox"/> skateboards <input type="checkbox"/> other recreational devices <input type="checkbox"/> other _____ • Is the path well designed for this purpose with no resulting hazards and conflicts? 	<input type="checkbox"/> <input type="checkbox"/> <input type="checkbox"/> <input type="checkbox"/> <input type="checkbox"/> <input type="checkbox"/>	<input type="checkbox"/> <input type="checkbox"/> <input type="checkbox"/> <input type="checkbox"/> <input type="checkbox"/> <input type="checkbox"/>	<input type="checkbox"/> <input type="checkbox"/> <input type="checkbox"/> <input type="checkbox"/> <input type="checkbox"/> <input type="checkbox"/>	<input type="checkbox"/> <input type="checkbox"/> <input type="checkbox"/> <input type="checkbox"/> <input type="checkbox"/> <input type="checkbox"/>
Comments					
		Rating	1 unsatisfactory	2 unsatisfactory but acceptable	3 satisfactory
6.2 Adjacent Traffic, Traffic Issues at Crossings and Driveways	<ul style="list-style-type: none"> • Are parked vehicles clear of pedestrian crosswalks? • Are drivers aware of the presence of pedestrians? • Do drivers give way to pedestrians at e.g. zebras, driveways, loading docks and when turning left? • Is oncoming traffic clearly visible to pedestrians (no obstructions blocking sight lines) at crossings? • Can children and people in wheelchairs clearly see approaching vehicles? • Is the driver's sight distance to the pedestrian crossing adequate with the drivers line of sight uninterrupted? • Are all types of pedestrians, including children and people in wheelchairs, visible to approaching vehicles? • Does the footpath continue uninterrupted through driveway crossovers? 	<input type="checkbox"/> <input type="checkbox"/> <input type="checkbox"/> <input type="checkbox"/> <input type="checkbox"/> <input type="checkbox"/> <input type="checkbox"/> <input type="checkbox"/>	<input type="checkbox"/> <input type="checkbox"/> <input type="checkbox"/> <input type="checkbox"/> <input type="checkbox"/> <input type="checkbox"/> <input type="checkbox"/> <input type="checkbox"/>	<input type="checkbox"/> <input type="checkbox"/> <input type="checkbox"/> <input type="checkbox"/> <input type="checkbox"/> <input type="checkbox"/> <input type="checkbox"/> <input type="checkbox"/>	<input type="checkbox"/> <input type="checkbox"/> <input type="checkbox"/> <input type="checkbox"/> <input type="checkbox"/> <input type="checkbox"/> <input type="checkbox"/> <input type="checkbox"/>
Comments					
		Rating	1 unsatisfactory	2 unsatisfactory but acceptable	3 satisfactory
Form 6 Overall Adjacent Traffic Rating					
			1 unsatisfactory	2 unsatisfactory but acceptable	3 satisfactory

Walkability Audit Forms

Form 7 Aesthetics and Amenities

Section Location (mark issues on map)		Yes	No	N/A	Don't know
7.1 Aesthetics and Amenities	• Is the route section:				
	- attractive and pleasant to walk around?	<input type="checkbox"/>	<input type="checkbox"/>	<input type="checkbox"/>	<input type="checkbox"/>
	- clear of litter, dumped rubbish, discarded items and graffiti?	<input type="checkbox"/>	<input type="checkbox"/>	<input type="checkbox"/>	<input type="checkbox"/>
	- clear of air pollution (e.g. diesel fumes and factory emissions)?	<input type="checkbox"/>	<input type="checkbox"/>	<input type="checkbox"/>	<input type="checkbox"/>
	- clear of noise pollution (e.g. construction, factories and traffic)?	<input type="checkbox"/>	<input type="checkbox"/>	<input type="checkbox"/>	<input type="checkbox"/>
• Does the section provide pedestrian oriented features?	<input type="checkbox"/>	<input type="checkbox"/>	<input type="checkbox"/>	<input type="checkbox"/>	
<input type="checkbox"/> benches	<input type="checkbox"/> low walls, sufficient to sit on	<input type="checkbox"/> rubbish bins	<input type="checkbox"/> drinking fountains	<input type="checkbox"/> public restroom	
<input type="checkbox"/> other _____					
Comments					
	Rating	1 unsatisfactory	2 unsatisfactory but acceptable	3 satisfactory	
Form 7 Overall Aesthetics and Amenities Rating		1 unsatisfactory	2 unsatisfactory but acceptable	3 satisfactory	
Additional comments regarding this section					