

CYCLONE WARNINGS

Bureau of Metrology (BoM) issues Tropical Cyclone (TC) Advice whenever a TC is expected to cause winds in excess of 62 km/h (gale force) over land. A TC Advice may be a Watch and/or a Warning, depending on when and where the gales are expected to develop.

For ongoing information from BoM during Tropical Cyclone periods refer to:

Recorded Cyclone Warning Service: 1300 659 210

Internet: <http://www.bom.gov.au/cyclone/>

Department of Fire and Emergency Services (DFES) will release a Cyclone Community Alert to keep people informed and safe. Alert Levels change to reflect the increasing risk to life and advises what you need to do before, during and after a cyclone. DFES issues the following cyclone alerts, Blue, Yellow, Red and All Clear. (see reverse side)

Internet: <https://www.emergency.wa.gov.au/>

NOTES

1. This Plan is not to be used for navigation, use the Department of Transport (DoT) nautical chart Exmouth WA900.
2. Positions on this plan are related to Geodetic Datum of Australia (GDA2020). For GPS use, this approximates WGS 84.
3. Sounding Datum is Lowest Astronomical Tide (LAT) which is 1.41m below AHD (2013).
4. Hydrographic survey composite includes the latest harbour survey from February 2022.
5. The mooring information in this Sheet should be read in conjunction with the DoT Exmouth Cyclone Mooring Guidelines.
6. Anchoring on seabed of Harbour is prohibited.
7. The Exmouth Marina Village (Canals) are under the control of the Shire of Exmouth.
8. Visiting vessels are to contact the Department of Transport Exmouth.

KEY CONTACTS NUMBERS

DoT Incident Control Centre: P: 1300 966 459

During a Cyclone "RED ALERT": (DFES SES Exmouth) P: 9949 1189
P: 13 3337

WA Police Exmouth: P: 9947 8700

Shire of Exmouth: P: 9949 3000

Base Marine: P: 9941 1433

All Emergencies: P: 000

DISCLAIMER & ACKNOWLEDGEMENT

The information contained in this publication is provided in good faith and believed to be accurate at time of publication. The State shall in no way be liable for any loss sustained or incurred by anyone relying on the information. This information in no way takes away the responsibilities of a Vessel's Master.

This Community Information Sheet has been prepared for community safety advice to preserve life and property. The support of the reader is crucial to the effectiveness in protecting life, property and the environment.

SERVICE WHARF CYCLONE MOORING INFORMATION

Cyclone mooring location number	Vessel size (M LOA)	Chain data	Minimum breaking load
1 to 5	20	19mm stud link	21.5 tonne
6 to 11	25	26mm stud link	56.7 tonne

Notes: Service Wharf Mooring shall be strictly in order from 1 to 5 and 6 to 11.
Service Wharf Mooring 1 cannot be occupied before trawler pens 1, 2 and 3 are filled.

To be read in conjunction with the DoT Exmouth Cyclone Mooring Guidelines.
Available at: <https://www.transport.wa.gov.au/imate/boating-emergencies-and-incidents.asp#28092>

SIGNIFICANT HEIGHTS

- 4.9m — Highest Recorded - Cyclone Vance
- 3.3m — Service Wharf and Charter Pen Deck
- 2.9m — HAT
- 2.4m — MHWS
- 1.8m — MHWN
- 1.5m — Mean Sea Level
- 1.4m — AHD
- 1.2m — MLWN
- 0.6m — MLWS
- 0.0m — LAT
- 0.1m — Lowest Recorded

Tropical Cyclone - Community Information Sheet

Exmouth Boat Harbour – 2022/23 Cyclone Season

1. Purpose of the Community Information Sheet

This Community Information Sheet has been developed to assist users of the Exmouth Boat Harbour during the period leading up to, the impact of and recovery from, a Tropical Cyclone. It is important that commercial and recreational boat users are well prepared and meet their Legislative requirements in having their own Cyclone Contingency Plans in place.

The Department of Transport (DoT) has a number of preparedness, response and recovery arrangements, including DoT Cyclone Management Plans to manage the impact of a Tropical Cyclone on its facilities.

2. Activation of the DoT Cyclone Management Plan

This DoT Cyclone Management Plan will be activated once a Cyclone Watch or Warning has been issued for the Exmouth area by the Bureau of Metrology (BoM). This activation is an internal process of the DoT.

3. DoT Appointed Incident Controller

An authorised DoT Incident Controller will be appointed upon activation of the plan to initiate cyclone preparedness actions for the Exmouth Boat Harbour, including some involving harbour users. The Incident Controller will be assisted by the appointment of a Harbour Controller in Exmouth.

4. Communication Mediums

While the DoT will not be providing scheduled radio broadcasts, frequencies will be monitored, while practical, through several local sources including:

- Exmouth Marine Rescue Group (EVMR) (call sign is "Marine Rescue Exmouth VMR 682") VHF 16 and 21 and 22 local repeater frequencies and HF 2182 kHz. Not manned continually but sporadically.

A 24 hour, 7 day/week HF service operates from the Water Police Coordination Centre that monitors the 4125, 6215 and 8291 kHz distress and calling frequencies. This service covers WA coastal waters within 200 nautical miles offshore. The closest transceiver is at Port Hedland and the call sign is "Coast Radio Hedland".

Key Contacts listing can be seen on the reverse side of this Sheet.

5. Responsibilities of Masters and Owners of Vessels

The information contained within this Community Information Sheet in no way replaces the existing legal obligations of owners and masters of vessels, nor does it seek to over-ride the responsibilities of a Master to take appropriate precautions for the safety of the crew, or to interfere with the Master's independent discretion.

In general terms, Vessel Owners or Masters should undertake the following tasks in order to prevent or minimise damage by ensuring:

- Mooring lines are strong enough, are not chuffed and are correctly tensioned.
- Where bow or stern mooring lines are inappropriately angled (say greater than 40°), it may be necessary to moor to the nearest piles. Ensure springs are in place.
- All Biminis and canopies should be removed.
- Roller jibs and mainsails furled to booms should be removed or securely tied to prevent them coming loose.
- All equipment such as dinghies should be removed from the decks and stored below or ashore or securely fastened.
- All running rigging on yachts is tight and securely fastened.
- Check that adequate fendering is in place on boats and that these are correctly located.
- Ensure that the length of the boat moored in each berth is no longer than the length designated for that berth.

6. Limited Number of Mooring Pens and Mooring Positions

It is important to recognise that the Exmouth Boat Harbour has a limited number of mooring pens and mooring positions. Every effort will be made to maximise the use of the Exmouth Boat Harbour, however Masters should be prepared (as part of their own Cyclone Contingency Plan) to seek alternate shelter if necessary.

Please note that the Exmouth Boat Harbour cannot guarantee to provide secure shelter and safety for vessels and crews in all weather and storm surge conditions.

7. Cyclone Emergency Welfare Centre

There are no suitable onshore Cyclone rated shelters at the Exmouth Boat Harbour for crew during a Cyclone and **all crews** must relocate to suitable shore based accommodation or the Shire of Exmouth Primary Emergency Welfare Centre. The Shire of Exmouth Primary Emergency Welfare Centre is located at the Shire Hall on Maidstone Crescent. Crews should bring clothing, toiletries and other personal effects with them to the Welfare Centre to assist local emergency management arrangements.

8. Tidal Storm Surge

Harbour users need to be aware that a significant positive storm surge may result from the extreme meteorological effects of a Tropical Cyclone. Storm surge may be exacerbated when a Cyclone impacts on a coastal community in conjunction with high tide. Masters of a Vessel need to factor in the effects of storm surge when mooring and preparing their Vessel.

9. Cyclone Mooring Arrangements

Mooring priority will be given to vessels covered by an existing mooring agreement. Mariners should be aware of submerged mooring chains from seabed mooring piles in the southern portion of the harbour basin, refer to the map on reverse side of this Sheet.

A Cyclone Mooring Guideline has been prepared by the DoT, and is available, to be read in conjunction with this Community Information Sheet. The Cyclone Mooring Guideline for Exmouth Harbour can be obtained from the DoT Exmouth Office or at the following web address <https://www.transport.wa.gov.au/imarine/boating-emergencies-and-incidents.asp#28092>

All vessels which have dedicated moorings at the Trawler Pen Moorings (TPM), Charter Boat Pens (CBP) and the Jetty B Pens (Floating) should be securely moored at least 24 hours before forecasted Gale Force winds.

10. Masters and Owners Actions during Alerts and Warnings

BoM Declares Tropical Cyclone WATCH or WARNING

- Initiate actions in line with vessel or Company cyclone contingency plan.

DFES-SES "BLUE ALERT" Declared

- If en route to Exmouth, establish/maintain contact with the Incident Controller.
- Plan to be secured in the harbour at least 24 hours before predicted Gale Force winds.
- Be aware of submerged mooring chains in southern portion of harbour basin.
- Ensure vessel has been adequately moored.
- Ensure sufficient fuel on board to clear the harbour after the Cyclone for a return journey.
- Secure all equipment and/or remove the equipment from the harbour precinct.

DFES SES "YELLOW ALERT" Declared

- Ensure vessel and area of responsibility have been secured.
- Relocate to the Shire of Exmouth – Emergency Welfare Centre or make other suitable arrangements.

DFES SES "RED ALERT" Declared

There are no actions defined during this phase of ALERT and appropriate rated shelter should be used for your own safety and observe standard DFES SES guidelines and procedures for a Tropical Cyclone.

DFES-SES "ALL CLEAR"

- If a Vessel has made use of seabed mooring chains, ensure the seabed mooring chains are correctly repositioned and mooring lines retrieved.
- Extreme caution is to be taken in the post impact phase of a Cyclone both on land and on the water and where hazards or damage is observed it is to be reported to the Incident Controller,
- When leaving the harbour from a berth or a dedicated cyclone mooring extreme caution is to be exercised as navigation aids may be displaced or missing and there could be additional floating/submerged hazards.

Note: Masters and Owners must consider their own "DUTY OF CARE" responsibilities to remain safe, to protect people, property and the environment.

This Community Information Sheet is available online from the Department of Transport at the following web address: <https://www.transport.wa.gov.au/imarine/boating-emergencies-and-incidents.asp#28092>

CYCLONE MOORING GUIDELINES

Section Contents

8.1	General	2
8.1.1	General Mooring Information.....	2
8.2	Mooring Arrangements by Location	5
8.2.1	Service Wharf - 20 Metre Moorings	5
8.2.2	Service Wharf - 25 Metre Moorings	6
8.2.3	Charter Boat Pens (Fixed)	8
8.2.4	Jetty B Pens (Floating).....	9
8.2.5	Trawler Pens	10
8.3	Minimum Mooring Guideline.....	11
8.3.1	Jetty B Pens - 20 Metre (Pens 2 to 19).....	11
8.3.2	Jetty B Pens - 25 Metre (Pens 21 to 24).....	12
8.3.3	Jetty B Pens - 12 to 15 Metre (Pens 1 and 25 to 39)	13
8.3.4	Charter Boat Pens	14
8.3.5	Trawler Pens	14
8.3.6	Service Wharf - 20 to 25 Metre	15

8.1 General

Cyclones have wind gusts in excess of 62 km/h around their centres and, in the most severe cyclones, gusts can exceed 280 km/h. Cyclone Advice's are prepared by the Bureau of Metrology (BoM) with the severity of a Cyclone being described in terms of categories ranging from 1 to 5 related to the zone of maximum winds.

Category of Tropical Cyclone	Strongest 3 second Gust (km/h)	Typical Effects
1	Less than 125 km/h Gales	Minimal house damage. Damage to some crops, trees and caravans. Boats may drag moorings.
2	125 - 164 km/h Destructive winds	Minor house damage. Significant damage to signs, trees and caravans. Heavy damage to some crops. Risk of power failure. Small boats may break moorings.
3	165 - 224 km/h Very destructive winds	Some roof and structural damage. Some caravans destroyed. Power failure likely.
4	225 - 279 km/h Very destructive winds	Significant roofing and structural damage. Many caravans destroyed and blown away. Dangerous airborne debris. Widespread power failures.
5	More than 280 km/h Extremely destructive winds	Extremely dangerous with widespread destruction.

Table 1: Description of cyclone categories

The pens and mooring facilities in Exmouth have been designed for winds generated by cyclonic conditions in accordance with the Australian Wind Loading Code AS1170.2, and with the length of vessel in each berth equal to or less than the designed length.

The Charter Boat pens and the Jetty B pens have been designed for a thirty second gust wind speed of 54.2m/sec which is equivalent to a Category 4 cyclone. This wind speed could be exceeded in a Category 4 or 5 Cyclone. The Trawler Pens and the Service Wharf cyclone moorings have been designed for a thirty second gust wind speed of 69 m/sec which is equivalent to a Category 5 cyclone.

8.1.1 General Mooring Information

All vessels which have dedicated moorings at the Trawler Pen Moorings (TPM), Charter Boat Pens (CBP) and the Jetty B Pens (Floating) should be securely moored at least 24 hours before predicted Gale Force winds.

Minimum Mooring Arrangements are detailed in Section 8.3 Minimum Mooring Guideline.

Typical mooring line loads for the various locations are given in Table 2 below. These loads will vary depending upon the mooring configuration including the angle of the line with respect to the centreline of the vessel

Vessel Length Overall (m)	Overall Pen Size (m)	Bow & Stern Line Loads (tonnes)	Spring Line Loads (tonnes)
Trawler Pens			
25	27	15	7
20	27	12	5
18	27	10	5
Charter Boat Pens & Jetty B Pens			
25	27	15	7
20	22	12	5
15	17	7	4
12	14	5	2
Cyclone Mooring Positions 1 to 5 and 6 to 11			
		Stern Lines	
20		15	
25		18	

Table 2: Typical Mooring Line loads for various mooring locations under category 5 cyclonic conditions

Note: Service Wharf Mooring occupants need to appreciate that Cyclone Mooring Positions 1 to 5 and 6 to 11 using seabed piles, need to be filled sequentially from 1 to 5 and 6 to 11 for the Service Wharf, noting that filling of positions 1-5 and 6-11 can occur simultaneously. Trawler pens 1, 2, and 3 must be filled before Service Wharf cyclone mooring 1 is filled.

The masters of vessels shall be responsible for ensuring:

- Vessel is adequately secured for cyclonic conditions;
- Mooring lines are serviceable,
- Mooring lines are of adequate capacity for the anticipated line loads,
- Mooring lines, to the extent practicable, are set to allow for the likely range in the water level, and
- Anchor points on the vessel will take the line loads without failing.

The Bow and Stern Line Loads tabulated in Table 2 are Minimum Safe Working Loads for severe cyclonic winds. A minimum Factor of Safety of 3 should be applied when selecting mooring lines (based on Breaking Load).

This is to allow for those factors which degrade the load capacity of mooring lines (abrasion, knots, over-stress, age, temperature, end of line configuration, etc).

For example: For a 25 metre vessel in a Charter Boat Pen, Table 2 indicates a Bow & Stern Line Load of 15 tonnes.

This is a Minimum Safe Working Load. When a Factor of Safety of 3 is applied, the mooring line must have a Minimum Breaking Load of 45 tonnes (ie. 3 x 15 tonnes).

Furthermore, masters of vessels will be responsible for ensuring that the mooring lines are correctly tensioned in accordance with accepted best practice, to avoid vessels swinging and hitting other vessels or the mooring/berthing structures.

The lines elasticity needs to allow for storm surge conditions, hence ***steel wire ropes should not be used.***

Note: During Cyclone Vance, the water level increased to approximately 2.3 metres above the predicted high water for the day.

As it is difficult to list Line Loads for all sizes of vessels, mooring line loads have been provided in Table 2 for the following vessel sizes:

- 12, 15, 20 and 25 metre vessels for the Charter Boat Pens;
- 25, 20 and 18 metre vessels for the Trawler Pen Moorings; and
- 20 and 25 metre vessels for those using the Service Wharf Cyclone Moorings.
- 12 and 15 metre vessels for those using the Jetty B Pens (Floating)

It is suggested that for vessels that do not equate to the sizes shown in Table 2, the next larger size mooring line load should be adopted (especially if a vessel is in a larger mooring pen).

It is important to note that the width of the fairway/passage between the Service Wharf and the Northern Spur Breakwater will be reduced to less than 50% of the normal navigable width, once vessels are moored in Cyclone Mooring Positions 1 to 5 and 6 – 11 (i.e. in front of the Service Wharf using seabed piles).

Consequently, there will be some restriction on vessel movements and mariners should exercise due care.

Cyclone moorings using seabed piles

The guidelines and sequence for mooring the 11 vessels to the seabed pile mooring system is described below and the recommended mooring arrangements are shown on the plan. The moorings are numbered 1 to 11 from the east to the west. **The Mooring sequences shall be strictly in the order of numbering (ie. 1, 2, 3, 4, 5 for the eastern most moorings and 6, 8, 9, 10, 11, for the western most moorings)** to avoid fouling of chains which criss-cross each other on the seabed.

8.2 Mooring Arrangements by Location

8.2.1 Service Wharf - 20 Metre Moorings

Mooring Position	Description/Location	Mooring Points	Remarks
1 to 5	<p>Located along the northern side of the eastern end of the Service Wharf with mooring No. 1 on the eastern end and No.5 on the western end. Mooring orientation: north-south. The stern of the vessels should be a nominal 10 metres away from the wharf face and may be varied to suit conditions.</p>	<p>Mooring 1: Seabed piles P2 & P4 and two bollards on the Service Wharf as indicated on the plan.</p> <p>Mooring 2: Seabed piles P3 & P5 and two bollards on the Service Wharf as indicated on the plan.</p> <p>Mooring 3: Seabed piles P4 & P6 and two bollards on the Service Wharf as indicated on the plan.</p> <p>Mooring 4: Seabed piles P5 & P7 and two bollards on the Service Wharf as indicated on the plan.</p> <p>Mooring 5: Seabed piles P6 & P8 and two bollards on the Service Wharf as indicated on the plan.</p>	<p>The anchor chains and bracelet for the seabed piles for each individual mooring is connected by a length of trace chain which runs along the seabed to the chafers (above the water line) on the Service Wharf. A short length of rope connects the end of the trace chain to the chafers. The identification number of the mooring has been painted on the respective chafers. For example, the anchor chains and bracelet from piles P2 and P4 for Cyclone Mooring Position No. 1 are connected by the trace chain and rope end which is tied to the chafer on which No. 1 has been painted. The stern lines of the vessels are to be secured to the bollards on the Service Wharf as shown on the plan.</p>

8.2.2 Service Wharf - 25 Metre Moorings

Mooring Position	Description/Location	Mooring Points	Remarks
6 to 11	<p>Located along the northern side of the western end of the Service Wharf with mooring No. 6 on the eastern end and No.11 on the western end. Mooring orientation: north-south. The stern of the vessels should be 10 metres away from the wharf face and may be varied to suit conditions.</p>	<p>Mooring 6: Seabed piles P9 & P11 and two bollards on the Service Wharf as indicated on the plan.</p> <p>Mooring 7: Seabed piles P10 & P12 and two bollards on the Service Wharf as indicated on the plan.</p> <p>Mooring 8: Seabed piles P11 & P13 and two bollards on the Service Wharf as indicated on the plan.</p> <p>Mooring 9: Seabed piles P12 & P14 and two bollards on the Service Wharf as indicated on the plan.</p> <p>Mooring 10: Seabed piles P13 & P15 and two bollards on the Service Wharf as indicated on the plan.</p> <p>Mooring 11: Seabed piles P14 & P16 and two bollards on the Service Wharf as indicated on the plan.</p>	<p>The anchor chains and bracelet for the seabed piles for each individual mooring is connected by a length of trace chain which runs along the seabed to the chafers (above the water line) on the Service Wharf. A short length of rope connects the end of the trace chain to the chafers. The identification number of the mooring has been painted on the respective chafers. For example, the anchor chains and bracelet from piles P9 and P11 for Cyclone Mooring Position No. 6 are connected by the trace chain and rope end which is tied to the chafer on which No. 6 has been painted. The stern lines of the vessels are to be secured to the bollards on the Service Wharf as shown on the plan.</p>

For mooring at each of these eleven Service Wharf Moorings, the anchor chain is to be picked with the respective trace chain, **preferably without disconnecting** the rope end of the trace chain attached to the Service Wharf chafers.

If disconnecting the rope end is essential, a small buoy shall be attached to the rope prior to disconnection. This will ensure that, should the rope end drop into the water, it will remain visible for retrieval purposes and will not possibly be lost on the seabed requiring divers for retrieval.

The use of vessel winches and divers to retrieve the trace chain and help expose the bracelets will assist the process. The bracelet is to be placed over the vessel forward mooring bollard.

Note that transportable 4 metre lengths of chain extension with shackles at either end are available to help secure the bracelet to the vessel bollards if required. These chain extensions may be placed over the vessel bollards and joined to the anchor bracelet to make mooring easier if difficulty is experienced trying to lift the bracelets over the vessel bollards. These extension chains should be taken on-board prior to commencing the mooring process and are available from the DoT Harbour Coordinator or Regional Officer.

8.2.3 Charter Boat Pens (Fixed)

The charter Boat pens are located at the northern end of the boat harbour. Pen sizes vary from 15 metre to 25 metre. Mooring Guidelines are given in Section 8.3.

Pens are designed for a 30 second gust wind speed of 54.2 m/sec which is equivalent to a Category 4 cyclone. This wind speed could be exceeded in a severe Cyclone.

Mooring lines need to be of adequate strength, not chuffed and correctly tensioned. The mooring lines and arrangement must be in accordance with the boat manufacturer's recommendation.



Figure 1 Charter Boat Pens – Fixed. Pen C1 is the eastern most (left) pen and C18 the western most pen

The clearance widths for Charter Boat Pens are given in the following Table – Note pen numbering commences at the western end.

Charter Pen	Clearance Width (metres)
C1 and C2	8.4
C3	7.4
C4 and C5	8.4
C6 and C7	7.4
C6 to C14	6.1
C15 to C18	5.4

8.2.4 Jetty B Pens (Floating)

Pens sizes shown on the plan are the maximum length of vessel allowed in pens.

Pens are designed for a 30 second gust wind speed of 54.2 m/sec which is equivalent to a Category 4 cyclone. This wind speed could be exceeded in a severe Cyclone.

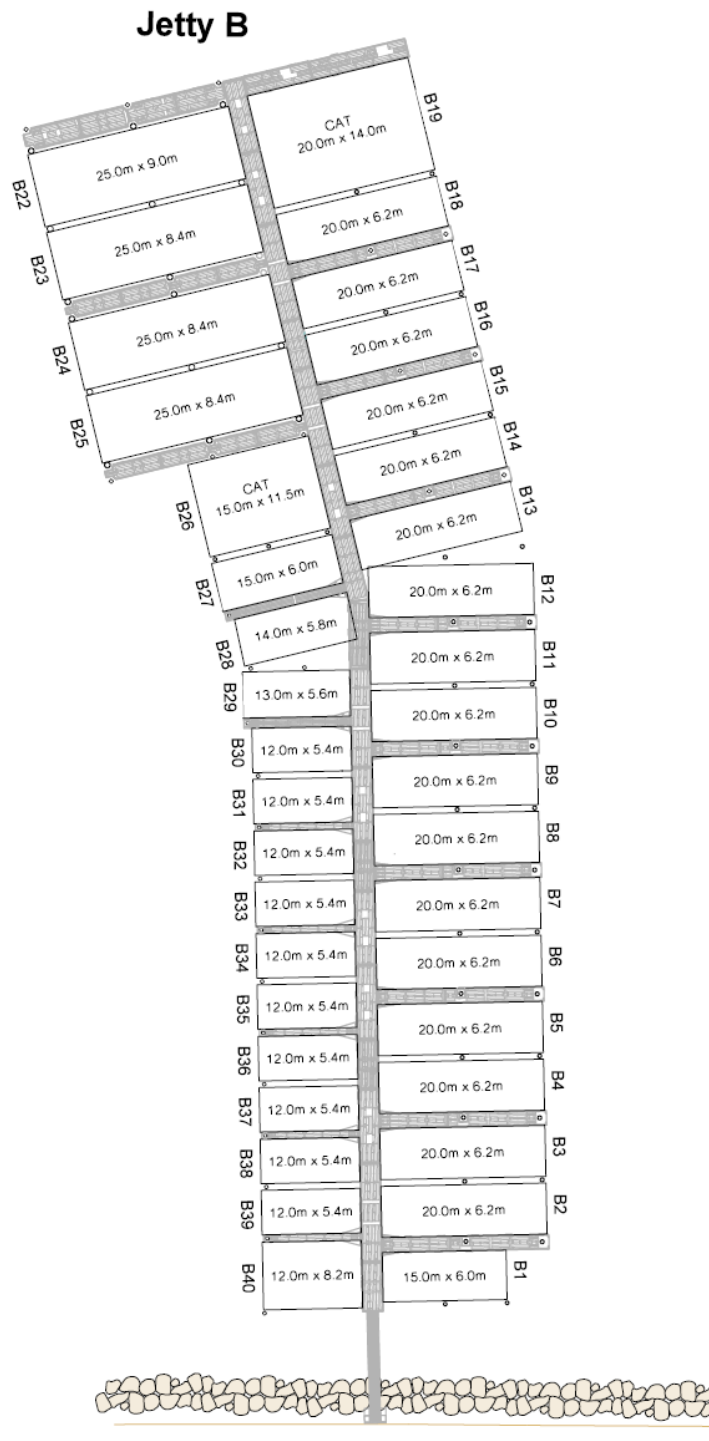

Figure 2: Jetty B Pens - Floating

Mooring lines need to be of adequate strength, not chuffed and correctly tensioned. The mooring lines and arrangement must be in accordance with the boat manufacturer's recommendation.

Other actions include:

- Roller jibs and mainsails furled to booms should be removed or securely tied to prevent them coming loose.
- All equipment such as dinghies should be removed from the decks and stored below or ashore or securely fastened.
- All running rigging on yachts to be tight and securely fastened.
- Adequate fendering to be in place on boats and correctly located.

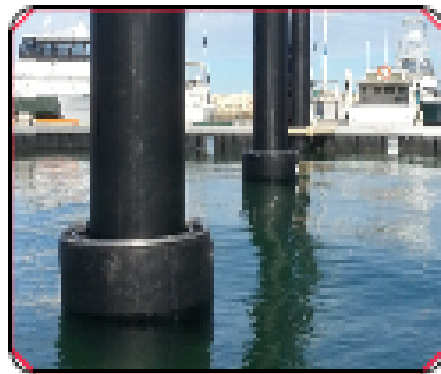

Figure 3: Typical Mooring Ring on Pile Guide (left) and Floating Mooring Ring (right)

8.2.5 Trawler Pens

The 4 trawler pens are located near the end of the southern breakwater. These pens are designed for 25 metre trawlers.

Pens are designed for a 30 second gust wind speed of 69 m/sec which is equivalent to a Category 5 cyclone. This wind speed could be exceeded in a severe Cyclone.

Mooring lines need to be of adequate strength, not chuffed and correctly tensioned. The mooring lines and arrangement must be in accordance with the boat manufacturer's recommendation.

Mooring rings are provided on the four corner piles for the attachment of bow, stern and spring lines.

8.3 Minimum Mooring Guideline

The following DoT Minimum Mooring Guideline has been developed to assist the Master of a Vessel and should be considered as the minimum requirement for securing a vessel prior to the impact of a Cyclone.

Mooring arrangements are generally specific for each vessel and correct mooring is the responsibility of the Owner/Master.

Note: These guidelines do not absolve the Master from meeting his/her responsibilities under legislation and that of his/her employer. All lines are to be in good condition and fully serviceable at the time of mooring.

8.3.1 Jetty B Pens - 20 Metre (Pens 2 to 19)

In cyclonic conditions, the minimum recommended mooring guideline arrangement for a 20 metre vessel in a Jetty B Pen is as follows;

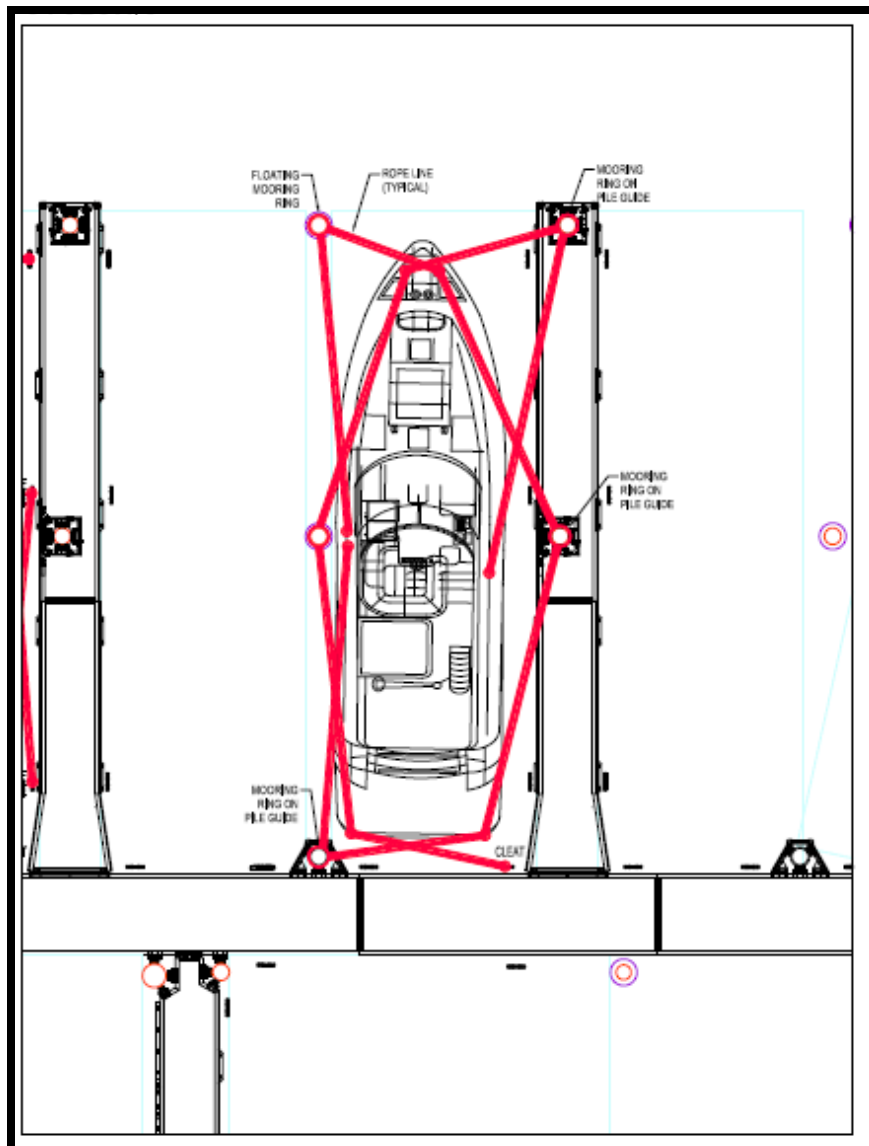

Figure 4: Minimum Mooring Guideline 20 Metre Jetty B Pens in Cyclonic Conditions

8.3.2 Jetty B Pens - 25 Metre (Pens 21 to 24)

In **cyclonic conditions**, the minimum recommended mooring guideline for 25 Metre Jetty B Pens is as follows;

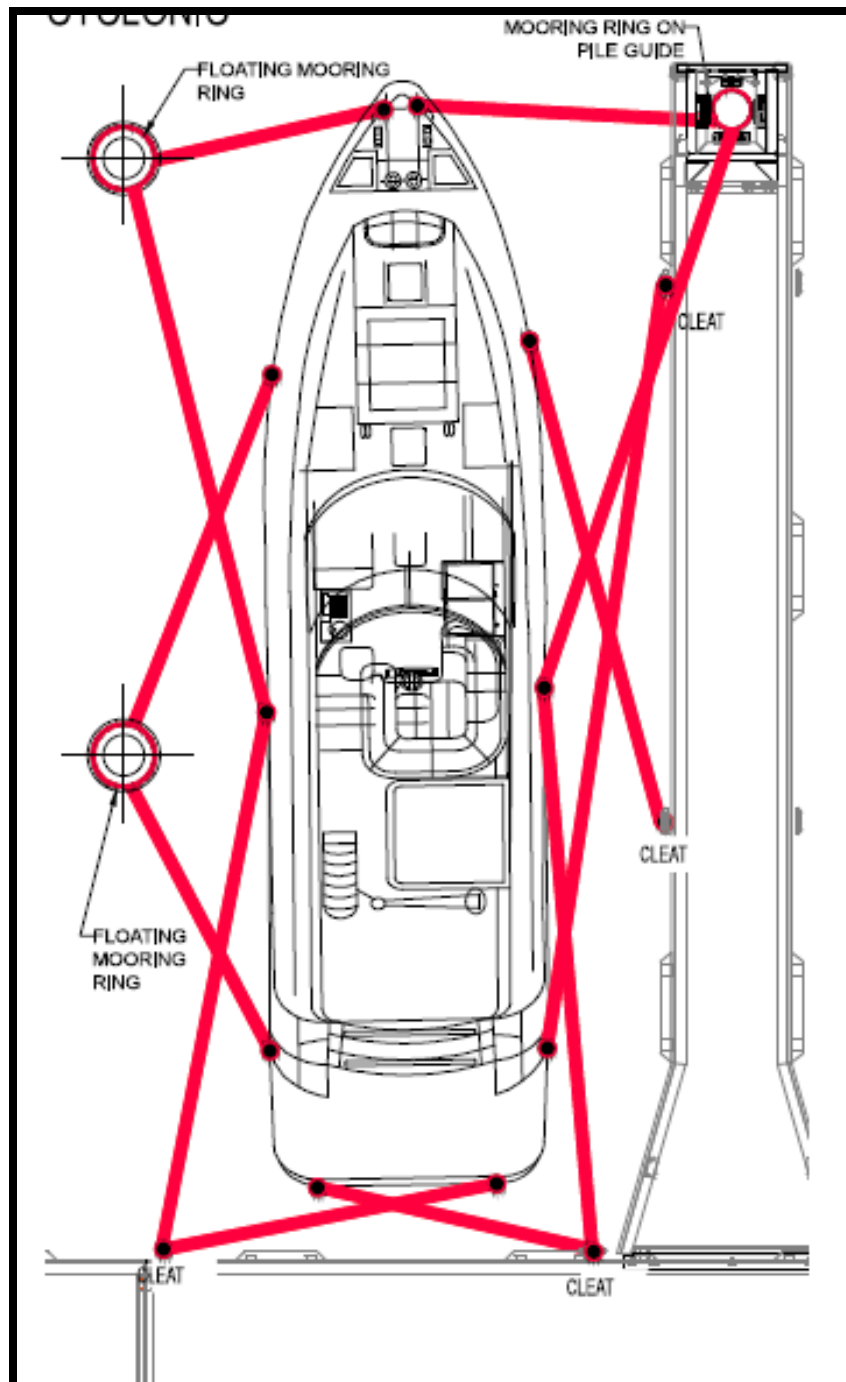

Figure 5: Minimum Mooring Guideline for 25 Metre Jetty B Pens in Cyclonic Conditions

Typical suggested mooring arrangement for 25 metre pens in cyclonic conditions

8.3.3 Jetty B Pens - 12 to 15 Metre (Pens 1 and 25 to 39)

In **cyclonic conditions**, the minimum recommended mooring guideline for 12 – 15 metre Jetty B Pens (Pens 29 to 39) is as follows;

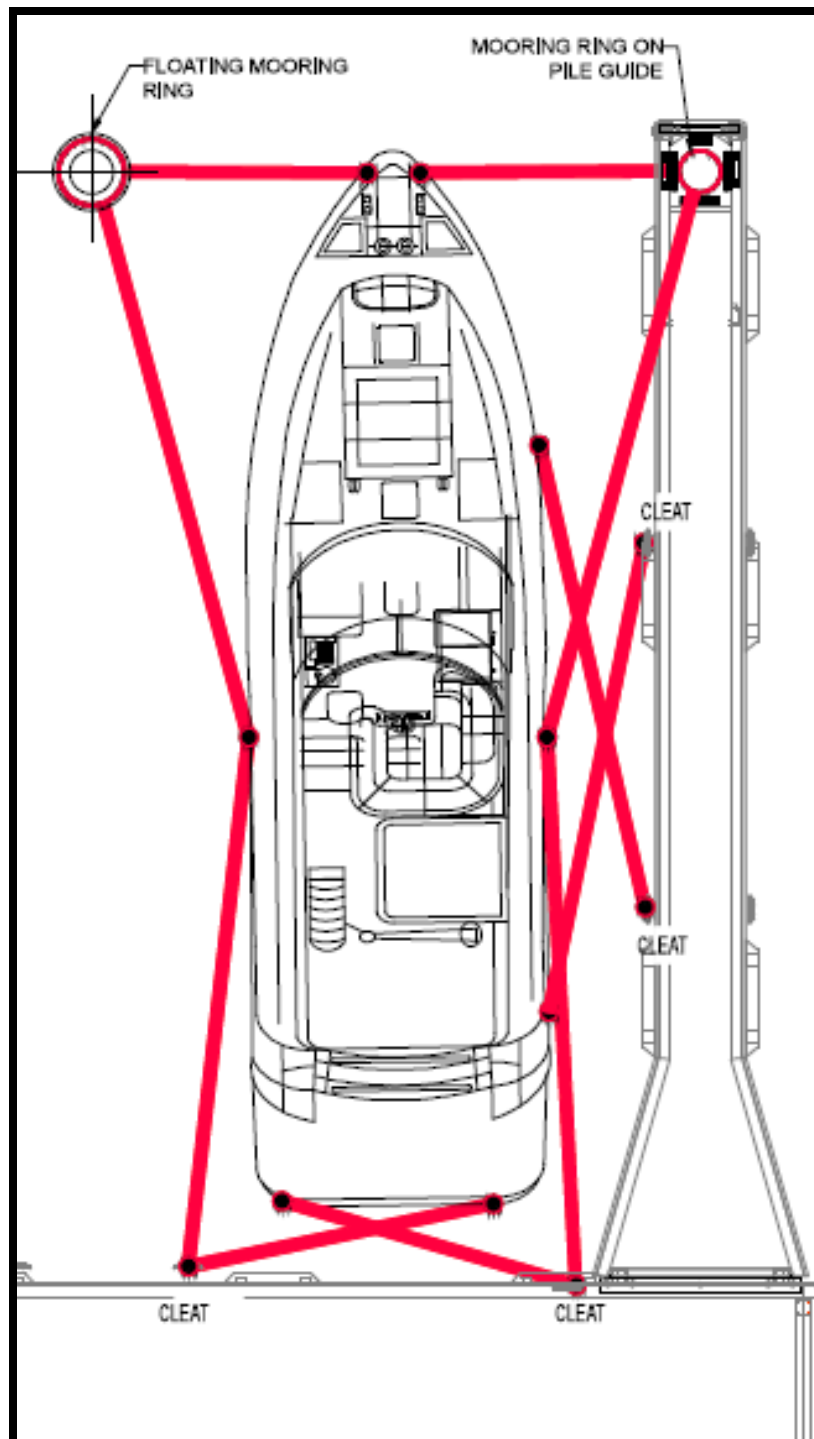

Figure 6: Minimum Mooring Guideline for 12 to 15 Metre Jetty B Pens in Cyclonic Conditions

8.3.4 Charter Boat Pens

In cyclonic conditions, the minimum mooring guideline for a Charter Boat Pen is as follows:

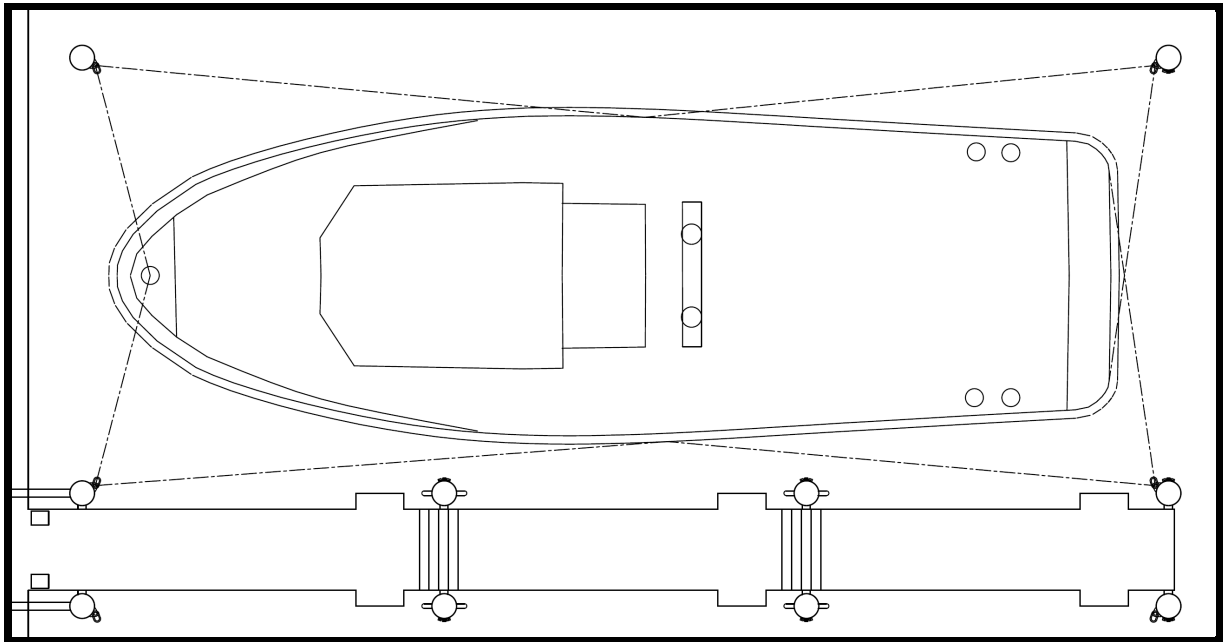

Figure 7: Minimum recommended Mooring Guideline for Charter Boat Pens in Cyclonic Conditions

8.3.5 Trawler Pens

In cyclonic conditions, the minimum recommended mooring guideline for Trawler boat pens is as follows:

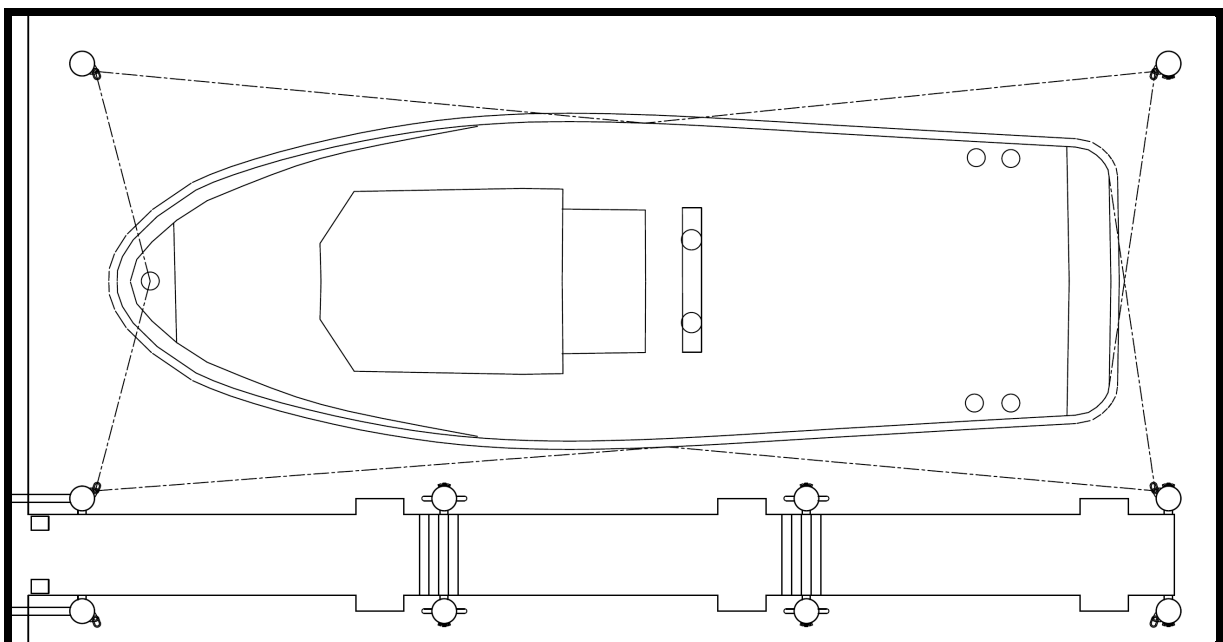

Figure 8: Minimum recommended Mooring Guideline for Trawler Pens in Cyclonic Conditions

Note – Vessels must be moored directly to the piles using the mooring rings provided.

8.3.6 Service Wharf - 20 to 25 Metre

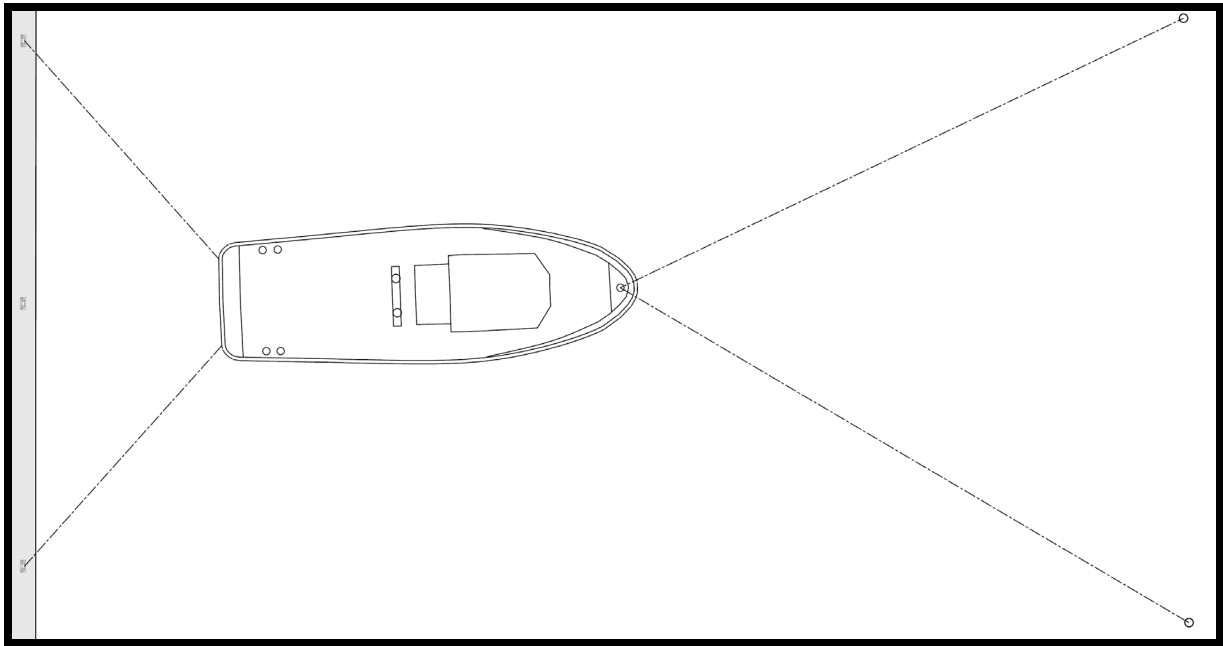
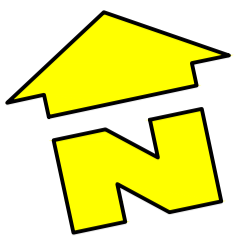
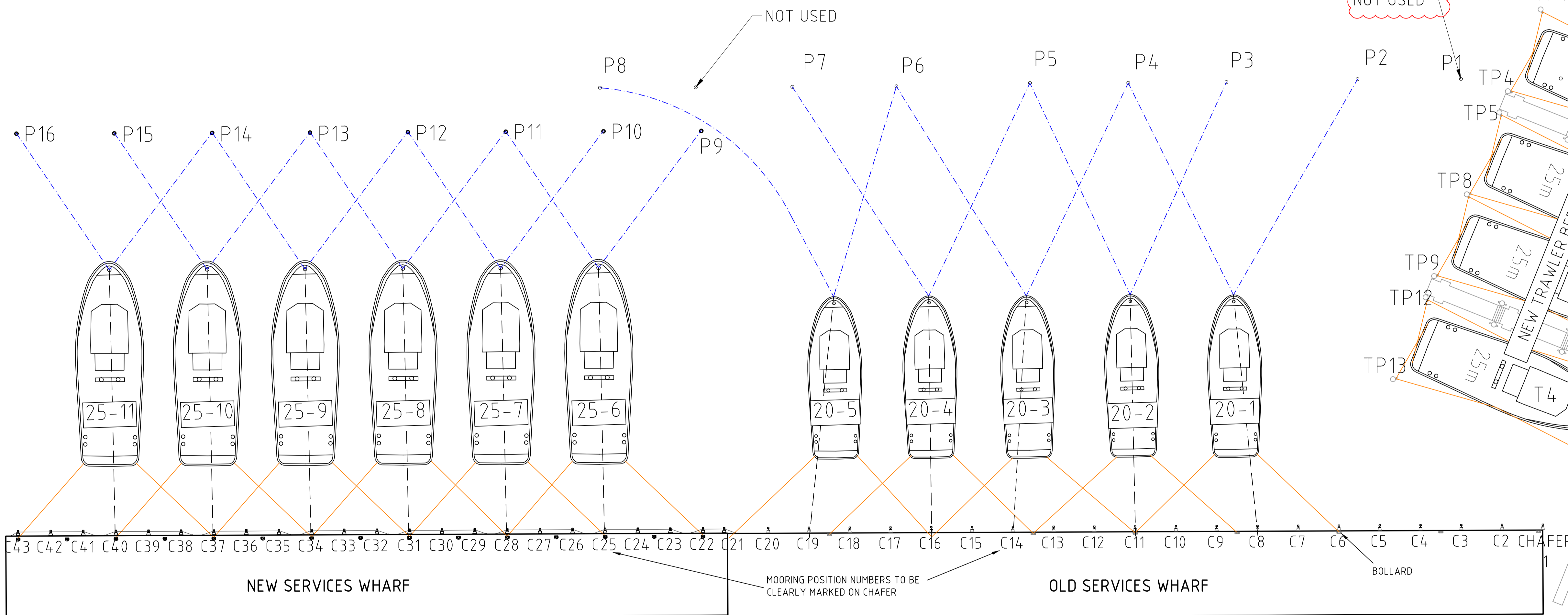

Figure 9: Minimum recommended Mooring Guideline for a Boat to the Service Wharf in Cyclonic Condition



LEGEND

- ANCHOR CHAIN ---
- TRACE CHAIN ---
- MOORING LINE ---
- CHAFFER NUMBER C1
- SEABED PILE P1
- TRAWLER PEN PILE TP1
- 25m BERTH NUMBER 25-6
- 20m BERTH NUMBER 20-1
- TRAWLER BERTH NUMBER T1



PLAN VIEW
SCALE 1:300
(SEE DWG 853-8-1 FOR PERSPECTIVE VIEW)

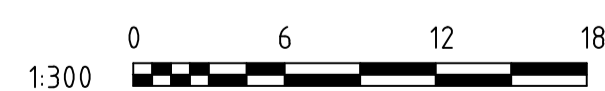

3	10.10.17	1 X 20m CYCLONE MOORING REMOVED	BS
2	21.07.17	RE- ISSUED AFTER NEW WHARF CONSTRUCTION	BS
1	10.08.05	ISSUED FOR CONSTRUCTION	AA
0	03.08.05	REVISED LAYOUT	AA
B	28.07.03	RE-ISSUED FOR CLIENT REVIEW	BGC
REV#	DATE	AMENDMENT	DRN DESIGN APPROVAL
ORIG SIZE A1	FILE NO	© CROWN COPYRIGHT	

GENERAL NOTES

- EXMOUTH_TOWN_MAY_2017.ECW AERIAL PHOTOGRAPHY BASE
- DERIVED FROM PLAN 1734-02-30

SCALE: 1:300 @ A1	DESIGNED	APPROVED
UNLESS OTHERWISE STATED DIMENSIONS IN METRES	CHECKED	APPROVED
HORIZ: MAP GRID OF AUSTRALIA BASED ON GDA94 - ZONE 50	DRAWN B STEPHENS	APPROVED
VERT: N/A	CHECKED	APPROVED
	PROJECT MANAGER N SIRAGUSA	AUTHORISED

Department of Transport		 EXMOUTH BOAT HARBOUR SERVICES WHARF CYCLONE MOORING LAYOUT PLAN - JULY 2017
DRAWING NUMBER 0853 - 08 - 02		
<small>BAR MEASURE INDICATES IF SCALES HAVE BEEN VARIED</small>		<small>REV#</small> 3

REFERENCES:
 1-DRG 853-6-1,-6-2,-6-3 & -6-4
 2-CYCLONE CONTINGENCY PLAN (LATEST ISSUE)

NOTE: BLUE CHAINS OVER BROWN

ABOVE LAYOUT TO BE READ IN CONJUNCTION WITH THE LATEST CYCLONE CONTINGENCY PLAN

CHAIN ASSEMBLY SEQUENCE

WHEN INSTALLING MOORING CHAIN ASSEMBLIES THE FOLLOWING SEQUENCE MUST BE USED:

BLUE OVER BROWN
 FOR OLD SERVICE WHARF CHAIN ASSEMBLY 5, 4, 3, 2 AND 1
 NEW SERVICE WHARF CHAIN ASSEMBLY 11, 10, 9, 8, 7 AND 6

WHEN RETRIEVING THE TRACE CHAIN SYSTEM FROM THE SEABED FLOOR THE FOLLOWING SEQUENCE MUST BE USED:

TRACE CHAIN ASSEMBLY 1, 2, 3, 4, 5 FOR THE OLD SERVICE WHARF
 AND 6, 7, 8, 9, 10, 11 FOR THE NEW SERVICE WHARF

BOAT MOORING SEQUENCE

CYCLONE BOAT MOORING SEQUENCE SHALL BE STRICTLY IN THE FOLLOWING ORDER:

BERTHS 1, 2, 3, 4 AND 5 FOR OLD SERVICE WHARF
 AND BERTHS 6, 7, 8, 9, 10 AND 11 FOR NEW SERVICE WHARF

AFTER THE CYCLONE ENSURE SEABED TRACE CHAINS ARE CORRECTLY REPOSITIONED AND BOAT MOORING LINES ARE FULLY RETRIEVED.

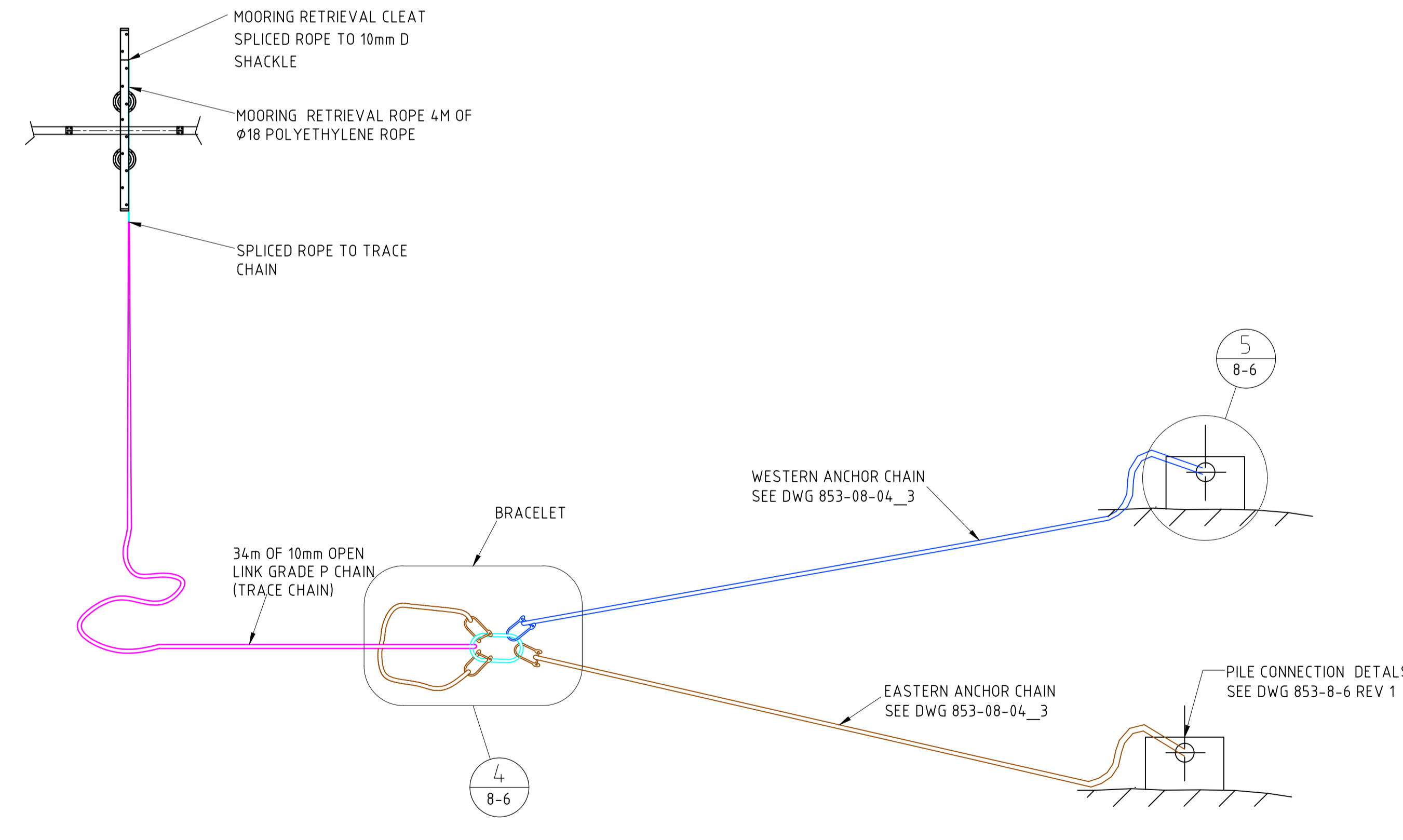
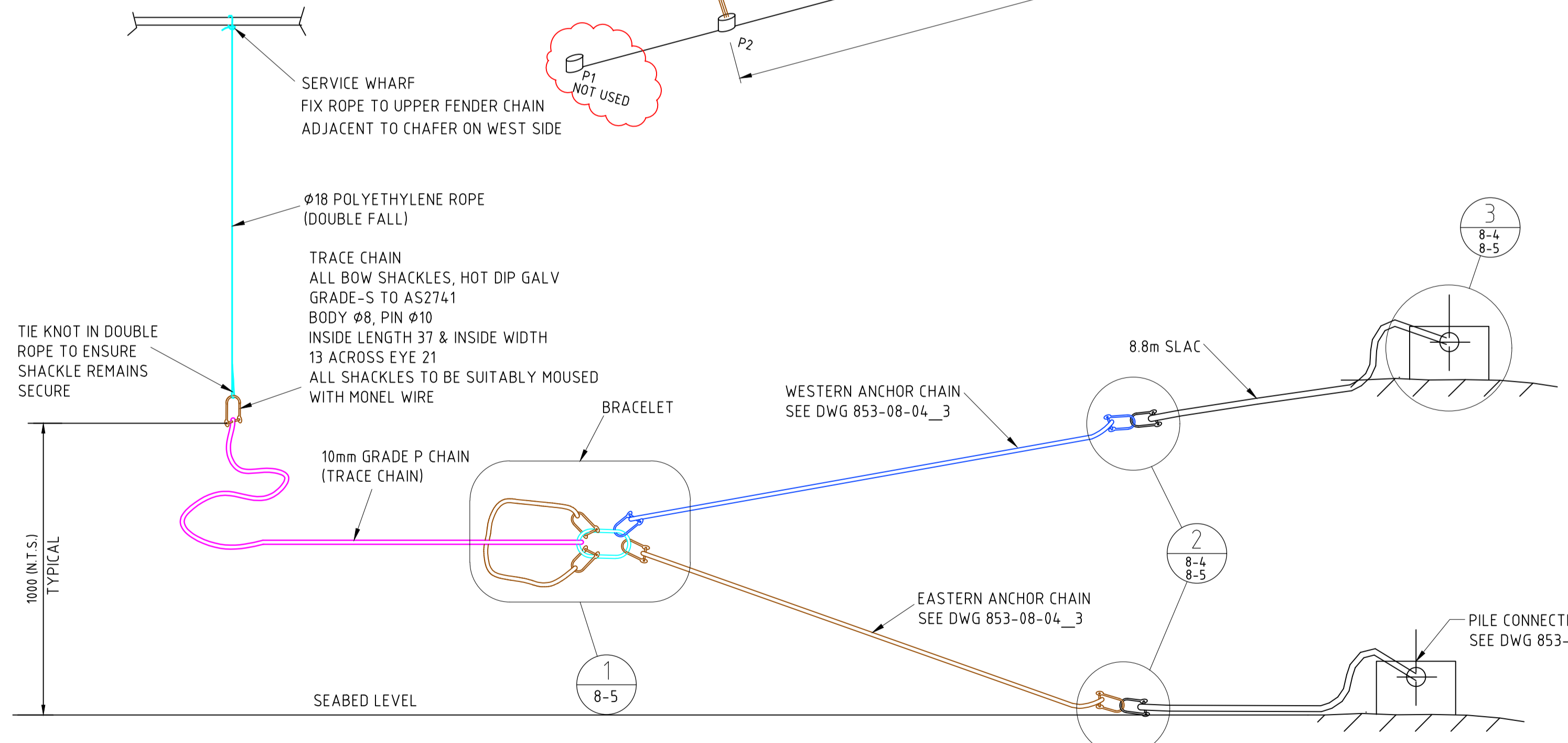
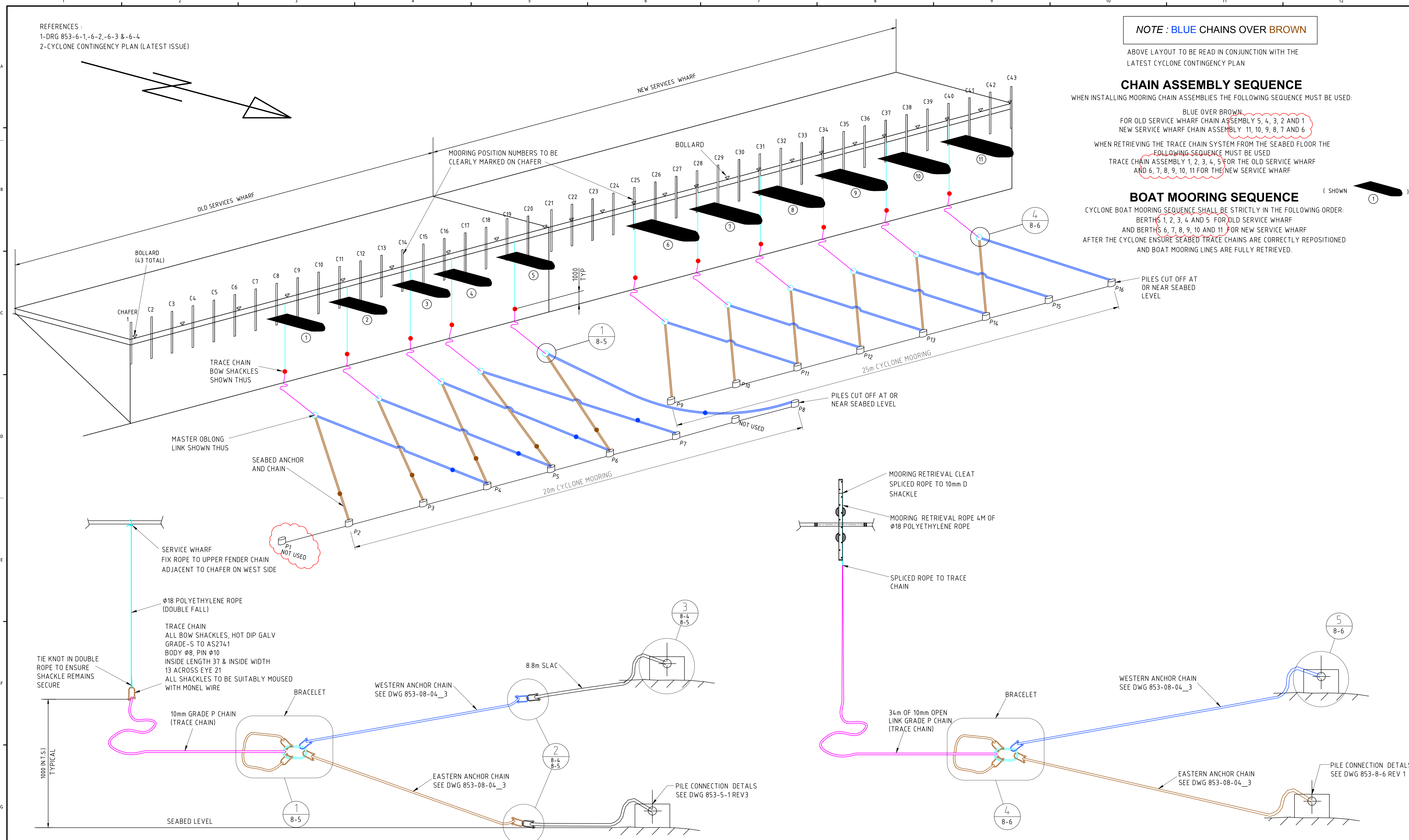

20m MOORING ANCHOR CHAIN ASSEMBLY AND POLYETHYLENE ROPE AND TRACE CHAIN

SCALE: N.T.S.
 NOTE: OLD SERVICE WHARF SYSTEM SHOWN (5 MOORINGS).

25m MOORING ANCHOR CHAIN ASSEMBLY AND POLYETHYLENE ROPE AND TRACE CHAIN

SCALE: N.T.S.
 NOTE: NEW SERVICE WHARF SYSTEM SHOWN (6 MOORINGS).

REV	DATE	AMENDMENT	DRN	DESIGN APPROVAL
4	10.10.17	1 X 20m CYCLONE MOORING REMOVED	BS	
3	21.07.17	RE- ISSUED AFTER NEW WHARF CONSTRUCTION	BS	
2	10.08.05	ISSUED FOR CONSTRUCTION	AA	
1	03.08.05	REVISED CHAIN DETAILS	AA	
0	03.03.04	ISSUED FOR CONSTRUCTION	RE	

GENERAL NOTES

SCALE: NOT TO SCALE	DESIGNED: B STEPHENS	APPROVED:
UNLESS OTHERWISE STATED DIMENSIONS IN METRES	CHECKED:	APPROVED:
HORIZ: N/A	DRAWN: B STEPHENS	APPROVED:
VERT: N/A	CHECKED:	APPROVED:
	PROJECT MANAGER: N SIRAGUSA	AUTHORISED:

Department of Transport

EXMOUTH - BOAT HARBOUR
 SERVICES WHARF CYCLONE MOORINGS
 UPGRADE SEABED TRACE CHAIN DETAILS
 PERSPECTIVE VIEW - JULY 2017

DRAWING NUMBER: 0853 - 08 - 01

REV: 4

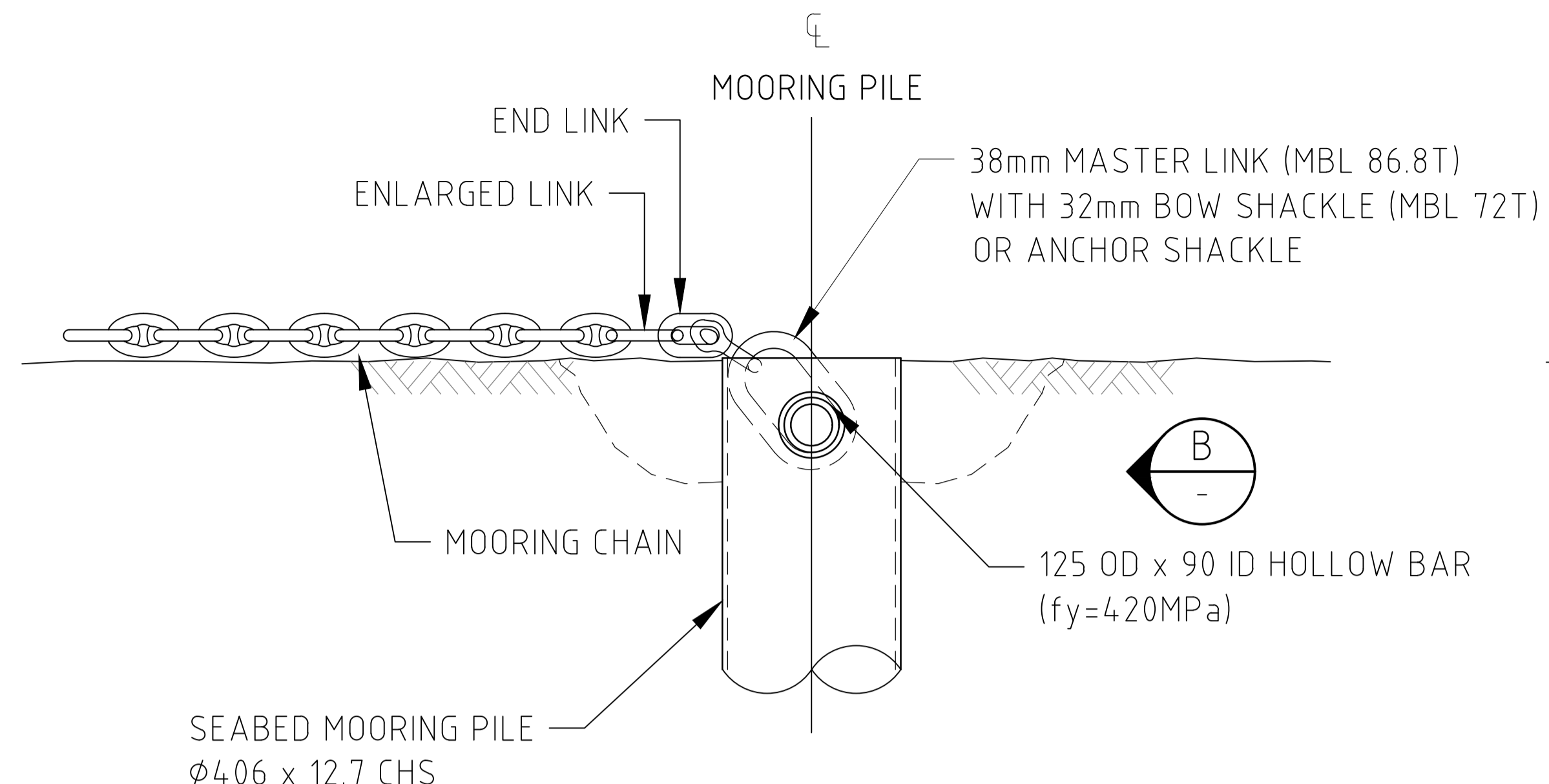

1 DETAIL
8-4 REV3 SCALE 1:20

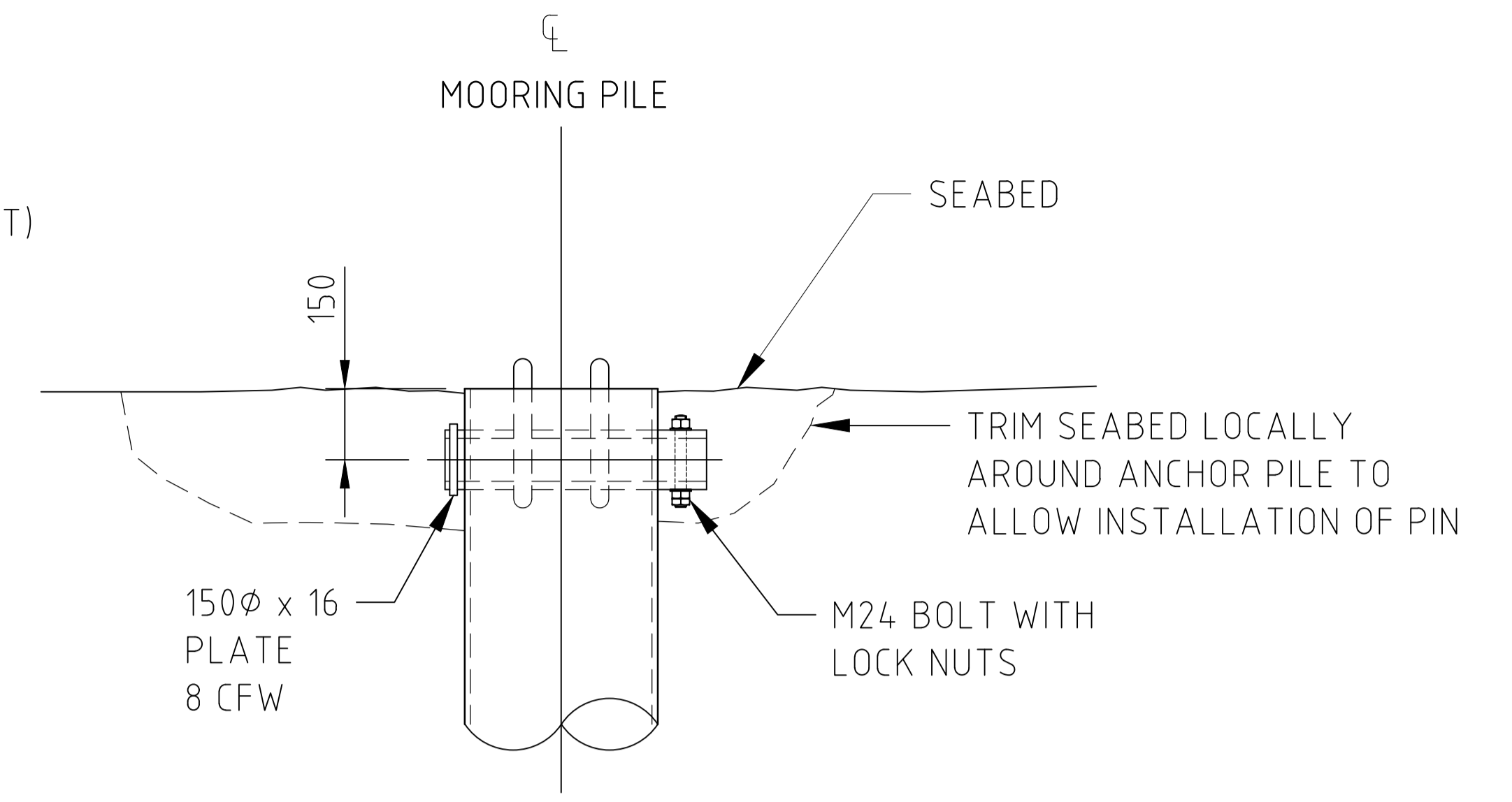

B ELEVATION
SCALE 1:20

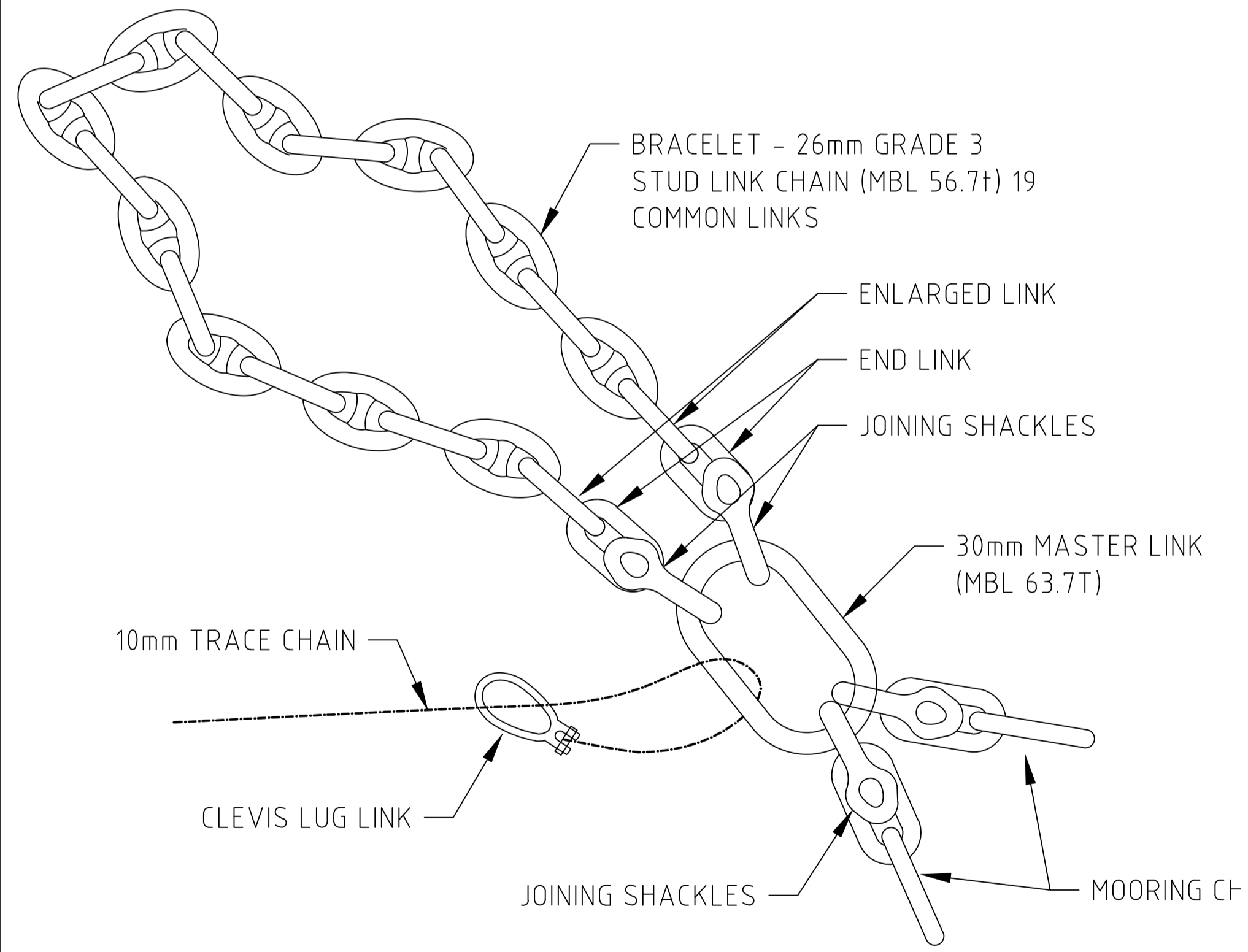

MOORING BRACELET DETAIL
NTS

MOORING PROCEDURE

- THIS MOORING PROCEDURE IS TO BE SUPERSEDED BY AN UPDATED CYCLONE CONTINGENCY PLAN.
1. POSITION VESSEL STERN-TO AT AN AVAILABLE CYCLONE MOORING.
 2. DEPLOY MOORING LINES TO THE BOLLARDS INDICATED ON THE PLAN WITH ENOUGH PLAY TO ACHIEVE A FINAL STANDOFF OF APPROXIMATELY 8m.
 3. COLLECT THE END OF THE TRACE CHAIN AND CONNECT TO THE WINCH OVER THE BOW
 4. WINCH THE CHAIN TO RETRIEVE THE BRACELET (EXPECTED WINCH-IN LOAD OF 0.7T)
 5. LOOP BRACELET AROUND THE BITT.
 6. RELEASE THE WINCH LOAD.
 7. MOORING CHAINS TO BE DEPLOYED FROM EAST TO WEST TO ALLOW CONSECUTIVE MOORING OF VESSELS.

DESIGN CRITERIA

RETURN PERIOD 500 YEARS (ULS)
WIND SPEED (30 GUST) 69m/s
WAVE HMAX = 0.6m

NOTE

1. ALL CHAINS AND SHACKLES FOR MOORINGS TO BE HEAVY DUTY GALVANISED STEEL UNLESS NOTED OTHERWISE.

GENERAL NOTES
1. DERIVED FROM PLAN 1734-02-31

1	21.07.17	ISSUED AFTER NEW WHARF CONSTRUCTION	BS
REV#	DATE	AMENDMENT	DRN
ORIG SIZE	FILE NO	© CROWN COPYRIGHT	
A1			

SCALE:	AS SHOWN @ A1	DESIGNED	APPROVED
	UNLESS OTHERWISE STATED DIMENSIONS IN METRES	CHECKED	APPROVED
HORIZ:	MAP GRID OF AUSTRALIA BASED ON GDA94 - ZONE 50	DRAWN	B STEPHENS
VERT:	EXMOUTH LAT WHICH IS 12.796 BELOW DMH 052 AND 1.395 BELOW AHD 1982 INFERRED	CHECKED	APPROVED
		PROJECT MANAGER	N SIRAGUSA
		AUTHORISED	

Department of Transport

EXMOUTH BOAT HARBOUR SERVICES WHARF 25M CYCLONE MOORING PILE CONNECTION AND FITTING DETAILS

DRAWING NUMBER **0853 - 08 - 06**

REV# 1

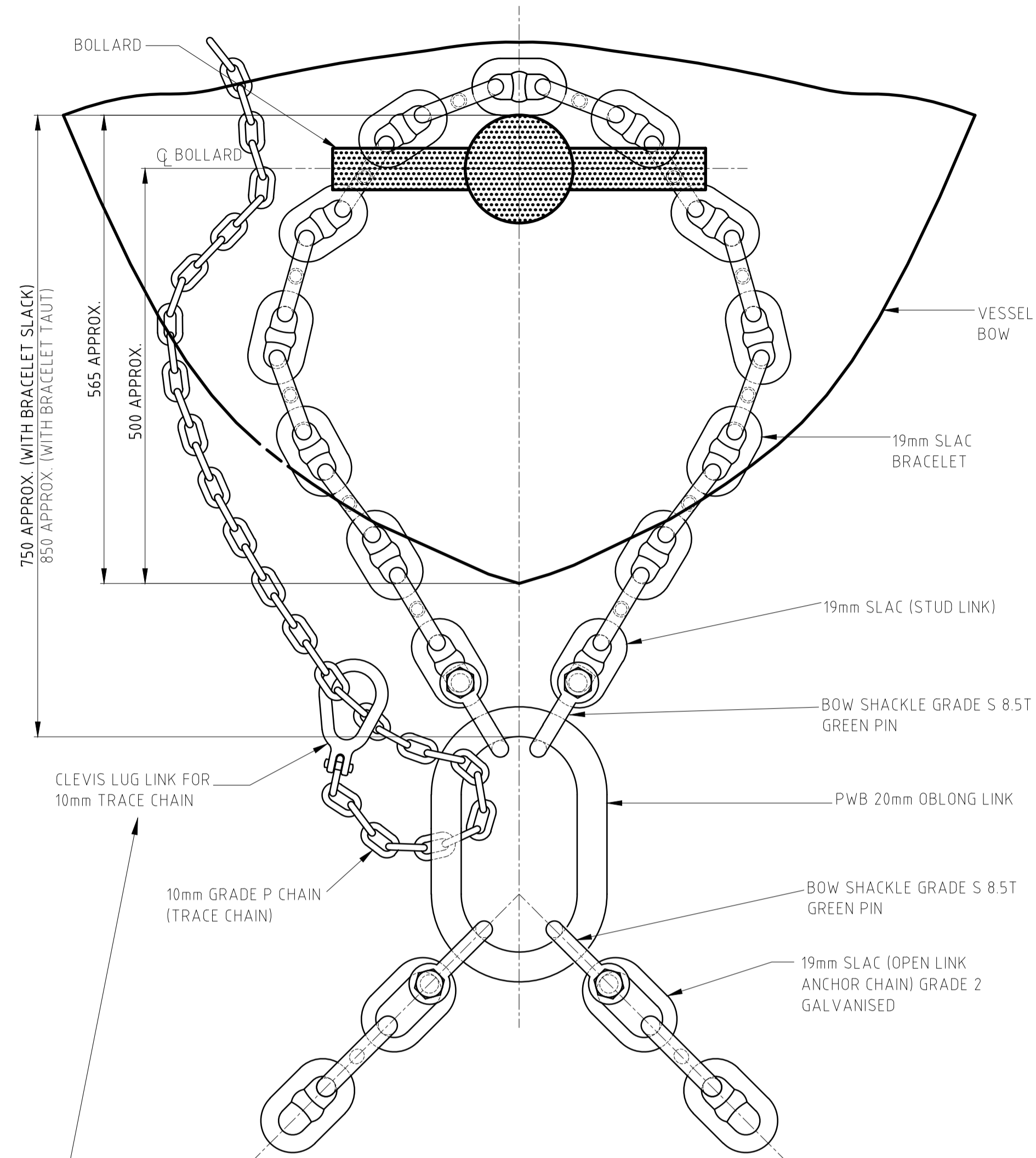

1 DETAIL - JUNCTION OF 2 LEGS (6 No. INCLUDING 1 SPARE)
8-1 NTS

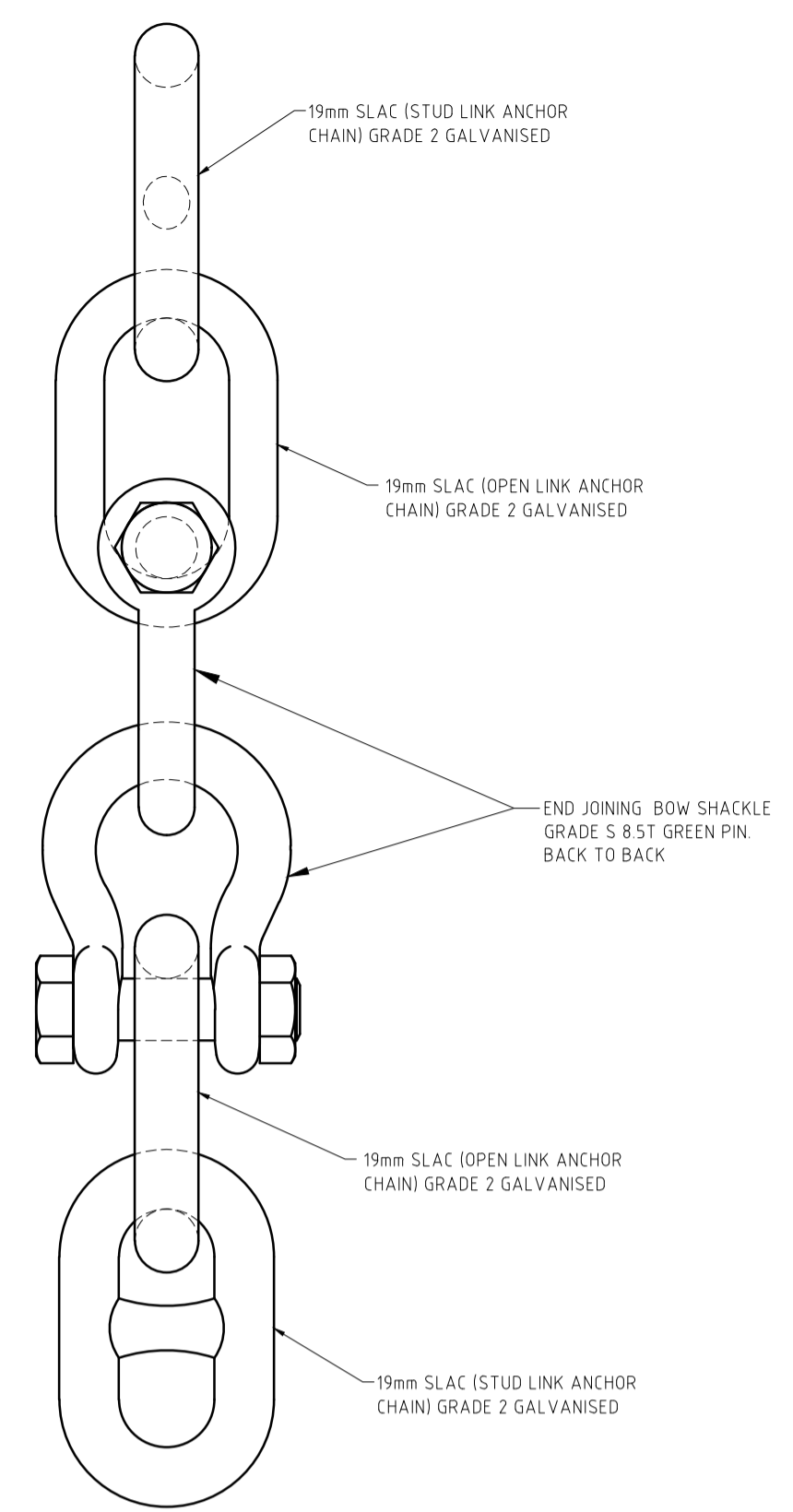

2 DETAIL - SPLICING LENGTH OF CHAIN TO SLAC (12 No. INCLUDING 1 SPARE)
8-1 NTS



Materials List - 20 m Service Wharf Cyclone Moorings		
Item	Description	Quantity
1	90 mm Galvanised Pin with lock nuts	6
2	PWB 20 mm Large Series Oblong Link - WLL 13.8 T	6
3	Gunnebo M-1310-10 Master Link	14
4	Bow Shackles Grade S 8.5 T Green Pin	60
5	19 mm Galvanised SLAC - 8.8 m lengths of Ground Chain	12
6	19 mm SLAC Riser Chain - Various Lengths Refer Table in Drawing 853-8-4	259.8 m
7	Bracelet - 19 mm Galvanised SLAC @ 1.85 m ea	6
8	Bow Shackles Grade S 0.75 T Green Pin	6
9	10 mm Galvanised Trace Chain - 6 x 32 m	192 m
10	Clevis Lug Link for 10 mm Trace Chain	6
11	Polyethylene Rope	6

- NOTES**
- 19mm SLAC - STUD LINK ANCHOR CHAIN - GRADE 2 GALVANISED.
 - ALL SHACKLES TO BE MOUSED
 - ABOVE INCLUDES 1 SPARE ASSEMBLY

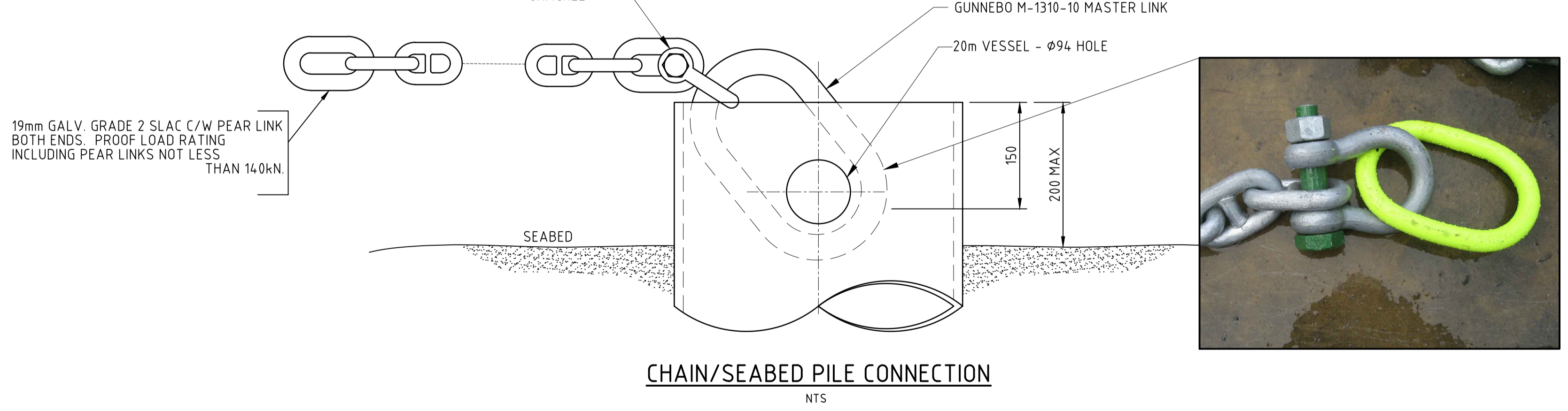
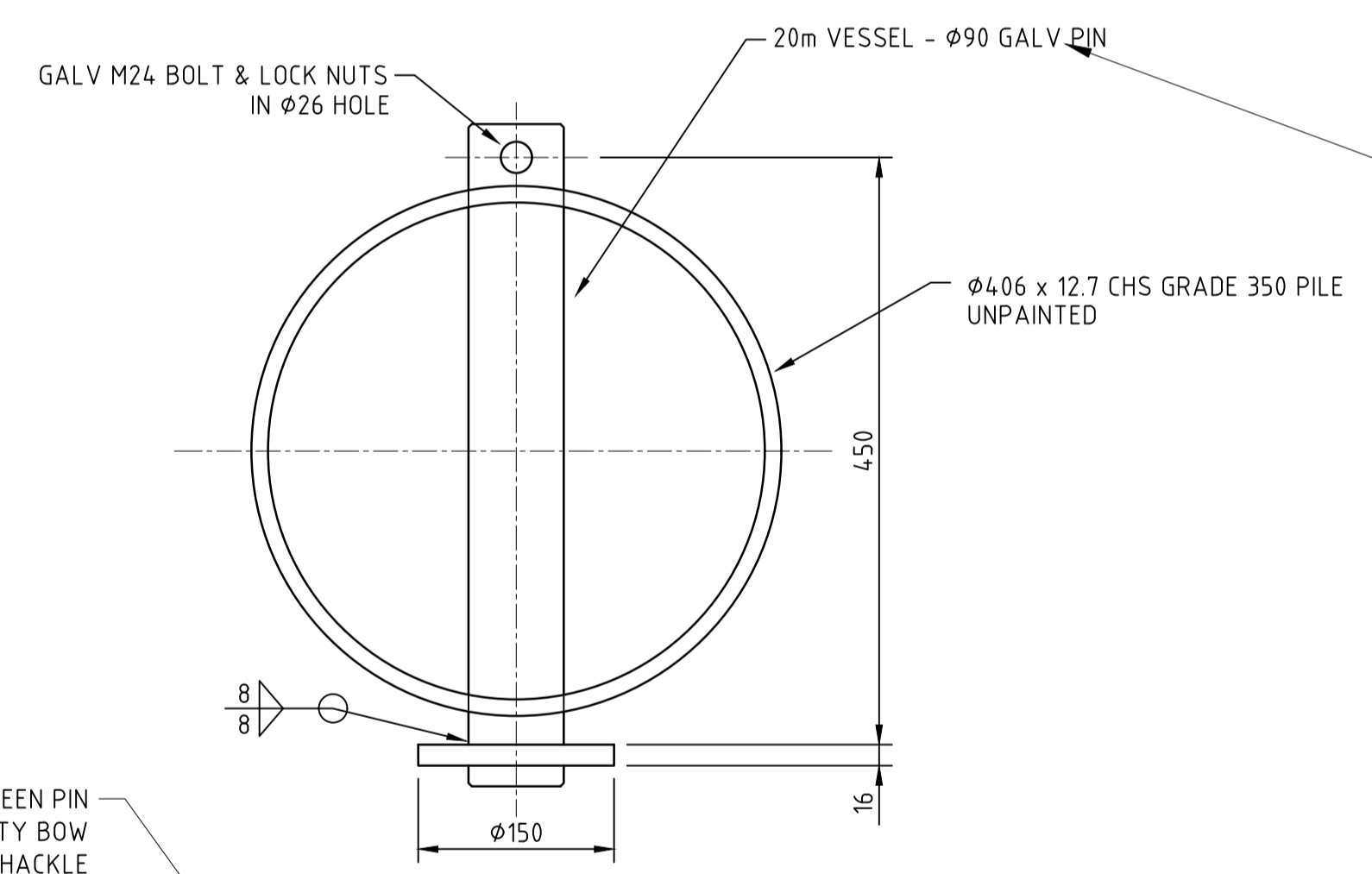

CHAIN/SEABED PILE CONNECTION
NTS

REV#	DATE	AMENDMENT	DRN	DESIGN APPROVAL
4	10.10.17	1 X 20m CYCLONE MOORING REMOVED	BS	
3	21.07.17	RE- ISSUED AFTER NEW WHARF CONSTRUCTION	BS	
2	10.08.05	ISSUED FOR CONSTRUCTION	AA	
1	03.08.05	REVISED CHAIN DETAILS	AA	
0	03.03.04	ISSUED FOR CONSTRUCTION	RE	

ORIG SIZE: A1
FILE NO: []
© CROWN COPYRIGHT

GENERAL NOTES

SCALE: NOT TO SCALE @ A1	DESIGNED: []	APPROVED: []
UNLESS OTHERWISE STATED DIMENSIONS IN MILLIMETRES (mm)	CHECKED: []	APPROVED: []
HORIZ: MAP GRID OF AUSTRALIA BASED ON GDA94 - ZONE 50	DRAWN: B STEPHENS	APPROVED: []
VERT: EXMOUTH LAT WHICH IS 12.796 BELOW DMH 052 AND 1.395 BELOW AHD 1982 INFERRED	CHECKED: []	APPROVED: []
	PROJECT MANAGER: N SIRAGUSA	AUTHORISED: []

Department of Transport

EXMOUTH BOAT HARBOUR SERVICES WHARF 20M CYCLONE MOORING PILE CONNECTION AND FITTING DETAILS

DRAWING NUMBER: 0853 - 08 - 05

REV# 4

CAD\EX0853-08-05_4.dwg